

PIR SENSOR INTERFACE

September 2006

FEATURES:

- Direct Interface with PIR Sensor
- Two-Stage Differential Amplifier
- Amplifier Gain and Bandwidth externally controlled
- True and Complementary Output Drives
- Separate digital filters for processing positive and negative input signals
- Single Pulse/Dual Pulse/ Concurrent Pulse Detection
- Adjustable Output Pulse Width
- Optional 5V Shunt Regulator Output
- 50µA Typical Supply Current
- Undervoltage Detection
- LS6511(DIP); LS6511-S (SOIC) - See Figure 1

APPLICATIONS:

Security system intrusion detection, automatic doors, motion triggered events such as remote animal photography.

DESCRIPTION (See Figure 5)

The LS6511 is a CMOS integrated circuit, designed for detecting motion from a PIR Sensor and initiating appropriate responses.

DIFFERENTIAL AMPLIFIER

Each stage of the two stage Differential Amplifier can be set to have its own amplification and bandwidth. The two inputs to the first stage allow for single-ended or differential connection to PIR Sensors. This stage can be biased anywhere in its dynamic range. The second stage is internally biased so that the Window Comparator's lower and higher thresholds can be fixed relative to this bias. Signal levels as low as 100µV can be detected.

WINDOW COMPARATOR

The Window Comparator provides noise filtering by enabling only those signals equal to or greater than a fixed threshold at the output of the Differential Amplifier to appear at the 2 outputs of the Window Comparator. One output detects positive input signals while the other output detects negative input signals.

COMPARATOR DIGITAL FILTER

The outputs of the Window Comparator are filtered so that motion must be present for a certain duration before it can be recognized and appear as pulses at the Digital Filter outputs. An external RC network sets the duration time. Nominal duration is 50ms.

MODE SELECT

A tristate input pin selects how the detected signals are processed. Single Pulse (SP) Mode is when detection from either a positive or negative input signal at the Digital Filter outputs will cause an LED/RELAY output to occur. Concurrent Pulse (CP) Mode is when detection from a positive and negative input signal must occur within a specific time before an output will occur. Dual Pulse (DP) mode is when any two detections within a specific time will cause an output to occur.
 SP Mode = 0; CP Mode = Open; DP Mode = 1.

PIN ASSIGNMENT - TOP VIEW

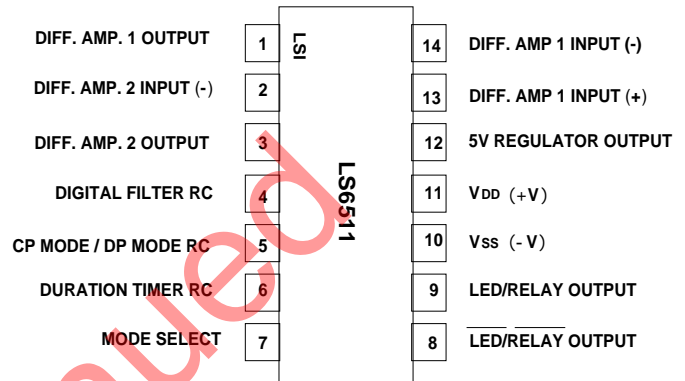

FIGURE 1

PROGRAMMABLE RETRIGGERABLE ONE-SHOTS

Positive and negative input signals at the digital filter outputs will generate retriggerable one-shot pulses. In the Concurrent Pulse Mode, outputs from each one-shot must occur together at some point in time to cause an output to occur. The one-shot pulse width is programmable using an external RC network. Typical pulse widths used vary between 1 and 12 seconds.

WINDOW TIMER

In the Dual Pulse Mode any two detections must occur within a timing window to cause an output to occur. The timing window is programmable using an external RC network. Typical windows are between 1 and 5 seconds.

OUTPUT DURATION TIMER

The duration timer is retriggerable and programmable using an external RC network. Typical duration times are between 0.5 and 15 seconds. Successive input detections will restart the timer.

OUTPUTS

The LED/RELAY Output is an open drain output that will sink current when an input signal is detected and processed and when the Power Supply drops below 3.7V (Typical) (Undervoltage Detection). The Undervoltage Detection will be removed when the Power Supply rises above 3.9V (Typical). The LED/RELAY Output performs identically but is opposite in polarity. The output can sink current from a relay coil returned to a positive voltage (VDD to 9.5V maximum).

SHUNT REGULATOR

The LS6511 includes a 5V Shunt Regulator Output which can be tied to the VDD Pin so that the circuit can be powered from a higher voltage power supply.

Note: See Figures 2, 3 and 4 for application schematics.

ABSOLUTE MAXIMUM RATINGS:

PARAMETER	SYMBOL	VALUE	UNIT
DC supply voltage	VDD - VSS	+7	V
Any input voltage	VIN	VSS - 0.3 to VDD + 0.3	V
Operating temperature	TA	-40 to +85	°C
Storage temperature	TSTG	-65 to +150	°C

ELECTRICAL CHARACTERISTICS:

(All voltages referenced to VSS, TA = -40°C to +55°C, 4.5V ≤ VDD ≤ 6.5V, unless otherwise specified.)

PARAMETER	SYMBOL	MIN	TYP	MAX	UNIT	CONDITIONS
SUPPLY CURRENT:						
VDD = 5V	IDD	-	50	75	μA	LED/RELAY, $\overline{\text{LED}}/\overline{\text{RELAY}}$
VDD = 4.5V - 6.5V	IDD	-	65	125	μA	and REGULATOR outputs not loaded
REGULATOR:						
Voltage	VR	5.00	5.75	6.25	V	-
Current	IR	-	-	10	mA	-
DIFFERENTIAL AMPLIFIERS:						
Open Loop Gain, Each Stage	G	70	-	-	dB	-
Common Mode Rejection Ratio	CMRR	60	-	-	dB	-
Power Supply Rejection Ratio	PSRR	60	-	-	dB	-
Input Sensitivity (Minimum Detectable Voltage to first amplifier when both amplifiers are cascaded for a net gain of 8,000)	Vs	100	-	-	μVp-p	TA = 25°C, with Amplifier Bandpass configuration as shown in Figure 3
Input Dynamic Range	-	0	-	1.75	V	-
Diff. Amp 2 Internal Reference	VIR	-	0.3VDD	-	V	-
COMPARATOR:						
Lower Reference	VTHL	-	VIR - 0.8V	-	V	At VDD = 5.75V
Higher Reference	VTHH	-	VIR + 0.8V	-	V	At VDD = 5.75V
DIGITAL FILTER:						
For 50ms Filter Time	RDF	-	2.2	-	M	-
	CDF	-	0.01	-	μF	-
ONE SHOT						
(1 Second)	ROS	-	2.2	-	M	-
	COS	-	0.22	-	μF	-
WINDOW TIMER						
(2.5 Second)	RWT	-	2.2	-	M	-
	CWT	-	0.68	-	μF	-
DURATION TIMER						
(5 Seconds)	RDT	-	2.2	-	M	-
	CDT	-	0.68	-	μF	-
OUTPUT DRIVE CURRENT (Vo = 0.5V Max.)	IO	-20	-	-	mA	VDD = 5V

The information included herein is believed to be accurate and reliable. However, LSI Computer Systems, Inc. assumes no responsibilities for inaccuracies, nor for any infringements of patent rights of others which may result from its use.

FIGURE 2. TYPICAL RELAY APPLICATION

NOTE 1: The relay coil is normally energized and the LED is off. When an alarm occurs, the relay coil becomes de-energized and the LED is turned on.

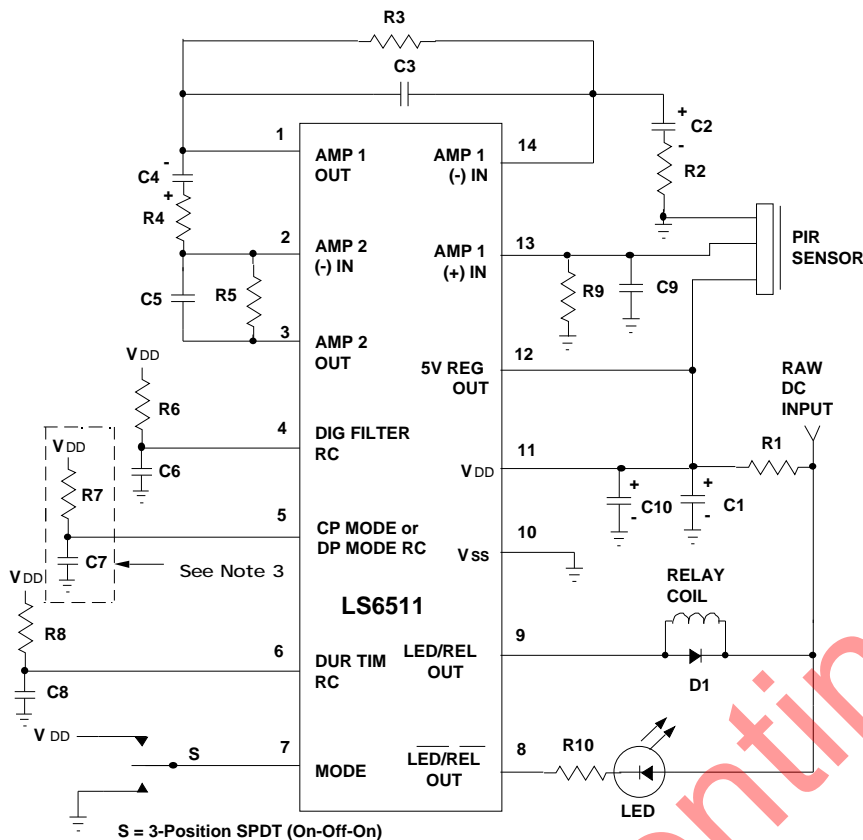

- R1 = See NOTE 2
 - R2 = 36k
 - R3 = 1.5M
 - R4 = 36k
 - R5 = 1.5M
 - R6 = 2.2M (Typical)
 - R7 = 2.2M (Typical)
 - R8 = 2.2M (Typical)
 - R9 = 36k
 - R10 = 2.2k (Typical)
 - C1 = 100µF
 - C2 = 10µF
 - C3 = 0.003µF
 - C4 = 10µF
 - C5 = 0.003µF
 - D1 = 1N4001
 - C6 = 0.01µF (Typical)
 - C7 = 0.22µF (CP Mode; Typical)
 - C7 = 0.68µF (DPMODE; Typical)
 - C8 = 0.22µF (Typical)
 - C9 = 0.1µF
 - C10 = 0.1µF
 - Relay = No typical P/N
- PIRs = Perkin-Elmer LHi 958, 978 (Typical)
 Nicera RE200B, SDA02-54 (Typical)

All Resistors 1/4W. All Capacitors 10V.

NOTE 2: R1 is selected to provide sufficient current to drive the LS6511 and PIR Sensor. Any surplus current is available to drive additional loads applied to the 5V Shunt Regulator output or is absorbed by the 5V Shunt Regulator. Refer to specifications for current limits.

NOTE 3: In SP Mode, R7 and C7 are not used and Pin 5 is tied to Vss.

NOTE 4: Adjust the value of R9 if the selected PIR Sensor causes the input static voltage at Pin 13 to be out of the Input Dynamic Range of 0V to 1.75V. (See Electrical Characteristics on Page 2)

NOTE 5: Sensitivity can be adjusted to a lower value by increasing the value of R2 or R4 or by decreasing the value of R3 or R5.

NOISE CONSIDERATIONS

Layout of any circuit using a high-gain PIR amplifier is critical. The PIR amplifier components should be located close to the amplifier pins on the chip in order to minimize noise pickup. The oscillator and relay drive components should be located away from the amplifier components.

Other steps that can help reduce noise is adding a ground shield backplane to the PCB and enhancing the filtering of VDD; i.e., adding a 0.1µF high frequency capacitor across C1 and increasing C1 to 220 µF.

FIGURE 3. INHIBITING OUTPUTS UPON POWER TURN-ON

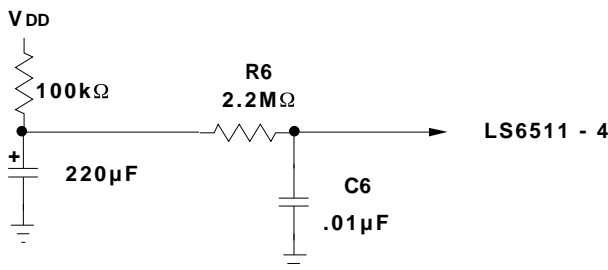

Using the typical application circuit as shown in Figure 2, the Outputs on Pins 8 and 9 occur on power-up because of the large settling time in the amplifier stages. In applications where this is not desirable, the digital filter oscillator must be disabled on power-up long enough to enable the PIR amplifiers to stabilize. Replacing the R6-C6 circuit shown in Figure 2 with the circuit shown in Figure 3 will disable the digital filter oscillator until the voltage across the 220µF capacitor reaches a value high enough for the oscillator to begin oscillating. Component values that can be changed to speed up stabilization include C2, C3, C4 and C5. C3 and C5 become 0.001µF and C2 and C4 become 10µF.

FIGURE 4. DIFFERENTIAL INTERFACE TO PIR SENSOR PAIR

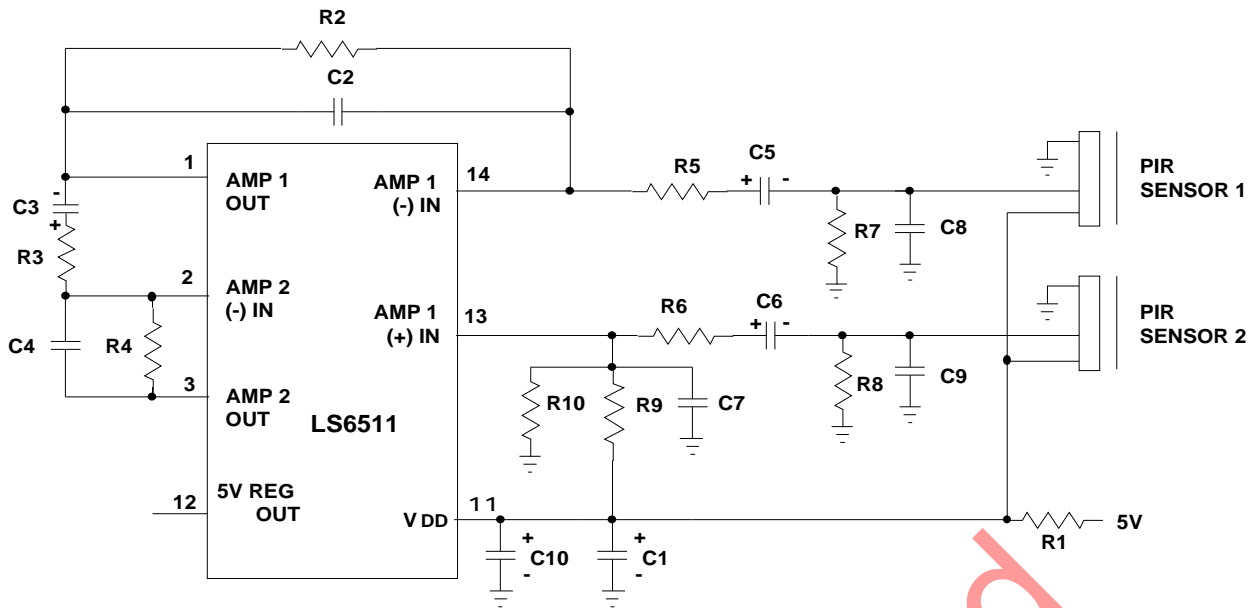

R1 = 1k	R6 = 36k	C1 = 100 μ F	C6 = 10 μ F
R2 = 1.5M	R7 = 36k	C2 = 0.003 μ F	C7 = 0.01 μ F
R3 = 36k	R8 = 36k	C3 = 10 μ F	C8 = 0.1 μ F
R4 = 1.5M	R9 = 5.6M	C4 = 0.003 μ F	C9 = 0.1 μ F
R5 = 36k	R10 = 2.4M	C5 = 10 μ F	C10 = 0.1 μ F

PIRs = Perkin-Elmer LHi 954, 958, 978, 874 or 878; Nicera RE200B, SDA02-54 (Typical)

All Resistors 1/4 W. All Capacitors 10V.

- NOTES:** 1) A pair of PIR Sensors may be used in applications where a wider optical field of view is needed.
 2) External 5V Regulator drives the LS6511 and PIR sensor.

FIGURE 5. LS6511 BLOCK DIAGRAM

