

QUADRATURE CLOCK CONVERTER

FEATURES:

- x1 and x4 mode selection
- Up to 16MHz output clock frequency
- Programmable output clock pulse width
- On-chip filtering of inputs for optical or magnetic encoder applications.
- TTL and CMOS compatible I/Os
- +4.5V to +10V operation (VDD - VSS)
- LS7083, LS7084 (DIP);
LS7083-S, LS7084-S (SOIC) - See Figure 1

DESCRIPTION

The LS7083 and LS7084 are CMOS quadrature clock converters. Quadrature clocks derived from optical or magnetic encoders, when applied to the A and B inputs of the LS7083 or LS7084, are converted to strings of Up Clocks and Down Clocks (LS7083) or to a Clock and an Up/Down direction control (LS7084). These outputs can be interfaced directly with standard Up/Down counters for direction and position sensing of the encoder.

INPUT/OUTPUT DESCRIPTION:

RBIAS (Pin 1)

Input for external component connection. A resistor connected between this input and VSS adjusts the output clock pulse width (TOW). For proper operation, the output clock pulse width must be less than or equal to the A, B pulse separation (TOW - TPS).

VDD (Pin 2)

Supply Voltage positive terminal.

VSS (Pin 3)

Supply Voltage negative terminal.

A (Pin 4)

Quadrature Clock Input A. This input has a filter circuit to validate input logic level and eliminate encoder dither.

B (Pin 5)

Quadrature Clock Input B. This input has a filter circuit identical to input A.

x4/x1 (Pin 6)

This input selects between x1 and x4 modes of operation. A high-level selects x4 mode and a low-level selects the x1 mode. In x4 mode, an output pulse is generated for every transition at either A or B input. In x1 mode, an output pulse is generated in one combined A/B input cycle. (See Figure 2.)

PIN ASSIGNMENT - TOP VIEW

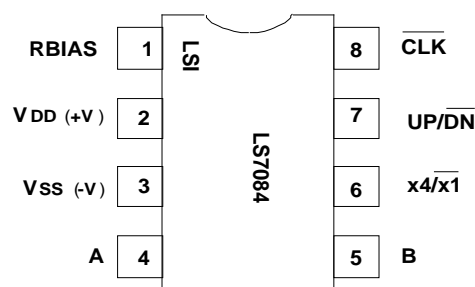
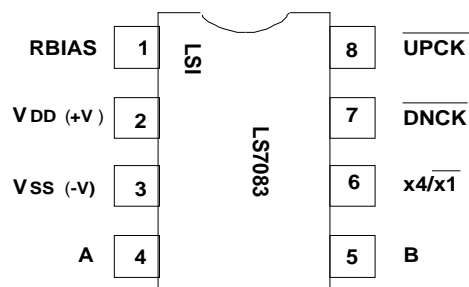

FIGURE 1

LS7083 - DNCK (Pin 7)

In LS7083, this is the DOWN Clock Output. This output consists of low-going pulses generated when A input lags the B input.

LS7084 - UP/DN (Pin 7)

In LS7084, this is the count direction indication output. When A input leads the B input, the UP/DN output goes high indicating that the count direction is UP. When A input lags the B input, UP/DN output goes low, indicating that the count direction is DOWN.

LS7083 - UPCK (Pin 8)

In LS7083, this is the UP Clock output. This output consists of low-going pulses generated when A input leads the B input.

LS7084N - CLK (Pin 8)

In LS7084, this is the combined UP Clock and DOWN Clock output. The count direction at any instant is indicated by the UP/DN output (Pin 7).

NOTE: For the LS7084, the timing of CLK and UP/DN requires that the counter interfacing with LS7084 counts on the rising edge of the CLK pulses.

ABSOLUTE MAXIMUM RATINGS:

PARAMETER	SYMBOL	VALUE	UNITS
DC Supply Voltage	V _{DD} - V _{SS}	11.0	V
Voltage at any input	V _{IN}	V _{SS} - 0.3 to V _{DD} + 0.3	V
Operating temperature	T _A	0 to +70	°C
Storage temperature	T _{STG}	-55 to +150	°C

DC ELECTRICAL CHARACTERISTICS:(All voltages referenced to V_{SS}, T_A = 0°C to 70°C.)

PARAMETER	SYMBOL	MIN	MAX	UNITS	CONDITION
Supply voltage	V _{DD}	4.5	10.0	V	-
Supply current	I _{DD}	-	6.0	µA	V _{DD} = 10V, All input frequencies = 0Hz RBIAS = 2M
x4/x1 Logic Low	V _{IL}	-	0.3V _{DD}	V	-
A, B Logic Low	V _{IL}	-	0.6	V	V _{DD} = 4.5V
		-	1.0	V	V _{DD} = 9V
		-	1.1	V	V _{DD} = 10V
x4/x1 Logic High	V _{IH}	0.7V _{DD}	-	V	-
A, B Logic High	V _{IH}	3.1	-	V	V _{DD} = 4.5V
		5.0	-	V	V _{DD} = 9V
		5.6	-	V	V _{DD} = 10V

ALL OUTPUTS:

Sink Current V _{OL} = 0.4V	I _{OL}	1.75	-	mA	V _{DD} = 4.5V
		5.0	-	mA	V _{DD} = 9V
		5.7	-	mA	V _{DD} = 10V
Source Current V _{OH} = V _{DD} - 0.5V	I _{OH}	1.0	-	mA	V _{DD} = 4.5V
		2.5	-	mA	V _{DD} = 9V
		3.0	-	mA	V _{DD} = 10V

TRANSIENT CHARACTERISTICS:(T_A = 0°C to 70°C)

PARAMETER	SYMBOL	MIN	MAX	UNITS	CONDITION
A, B inputs: Validation Delay	T _{VD}	-	85	ns	V _{DD} = 10V
		-	100	ns	V _{DD} = 9V
		-	160	ns	V _{DD} = 4.5V
A, B inputs: Pulse Width	T _{PW}	T _{VD} + T _{OW}	Infinite	ns	-
A to B or B to A Phase Delay	T _{PS}	T _{OW}	Infinite	ns	-
A, B frequency	f _{A, B}	-	$\frac{1}{2T_{PW}}$	Hz	-
Input to Output Delay	T _{DS}	-	120	ns	V _{DD} = 10V
		-	150	ns	V _{DD} = 9V
		-	235	ns	V _{DD} = 4.5V Includes input validation delay
Output Clock Pulse Width	T _{OW}	50	-	ns	See Fig. 4 & 5

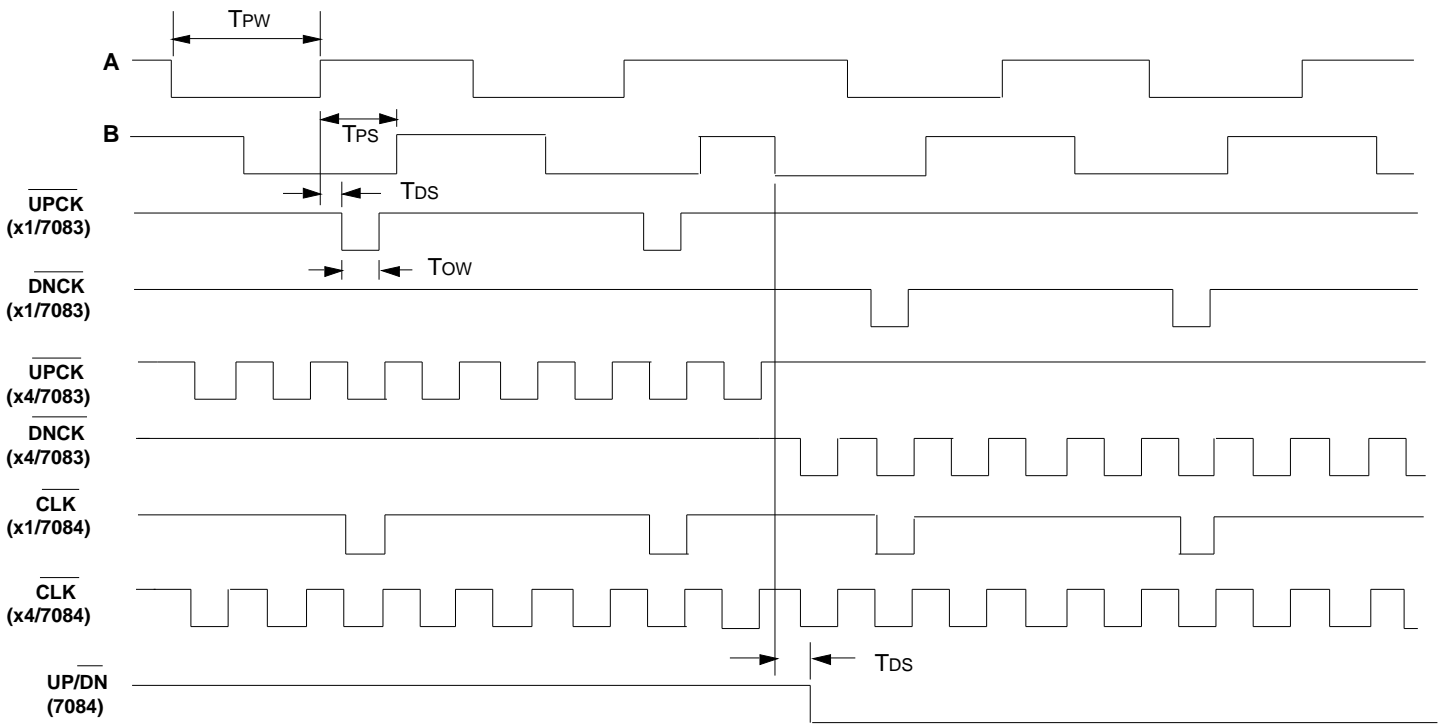

FIGURE 2. LS7083/LS7084 INPUT/OUTPUT TIMING DIAGRAM

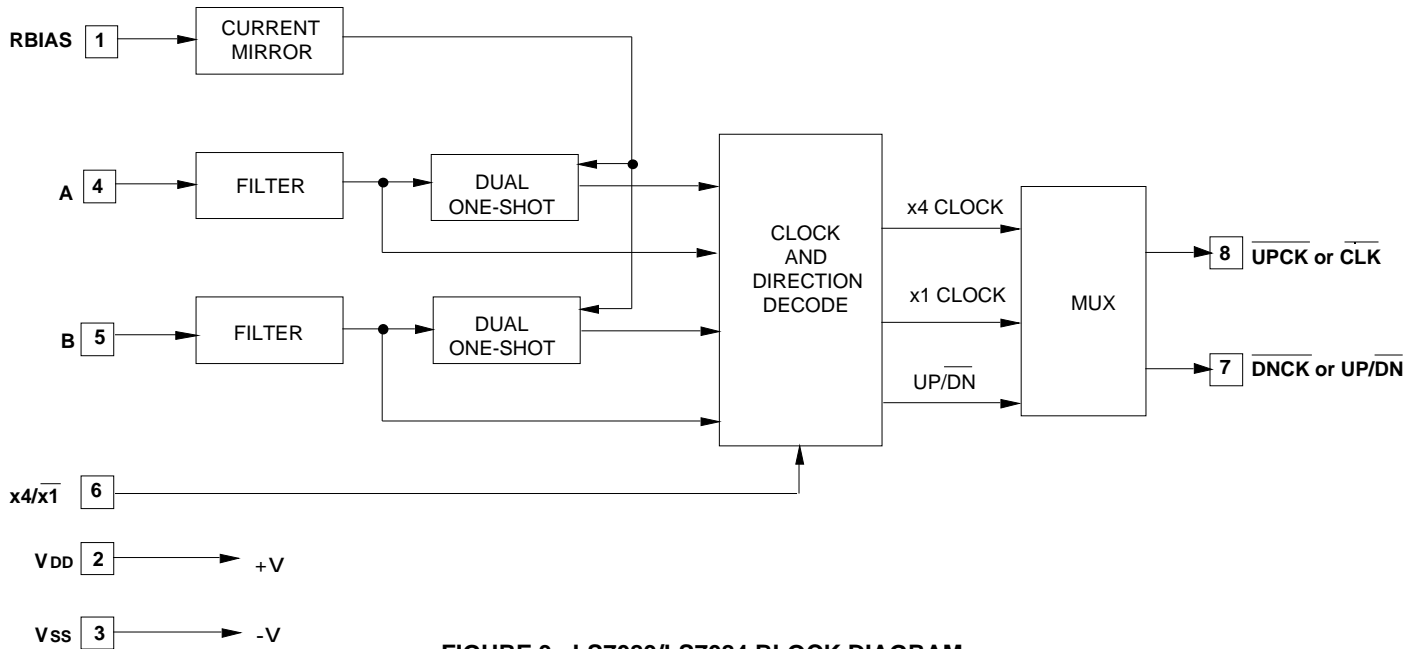

FIGURE 3. LS7083/LS7084 BLOCK DIAGRAM

The information included herein is believed to be accurate and reliable. However, LSI Computer Systems, Inc. assumes no responsibilities for inaccuracies, nor for any infringements of patent rights of others which may result from its use.

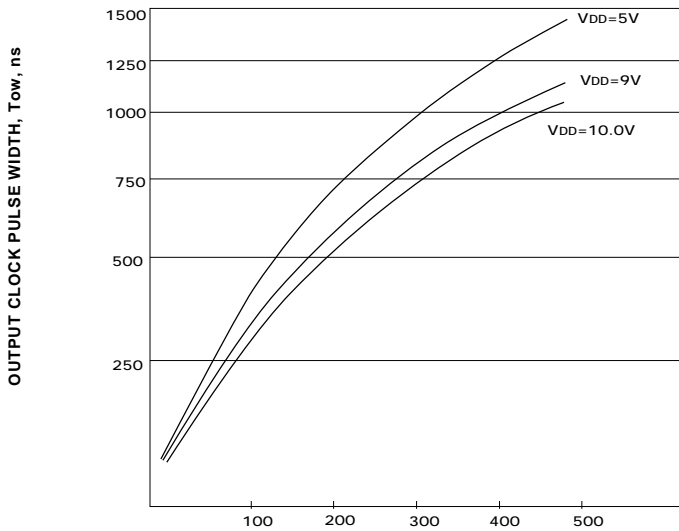

Figure 4. Tow vs RBIAS, kΩ

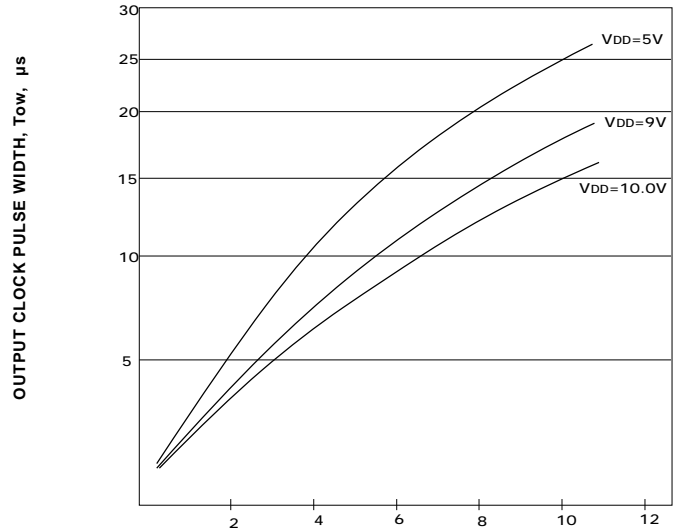

Figure 5. Tow vs RBIAS, MΩ

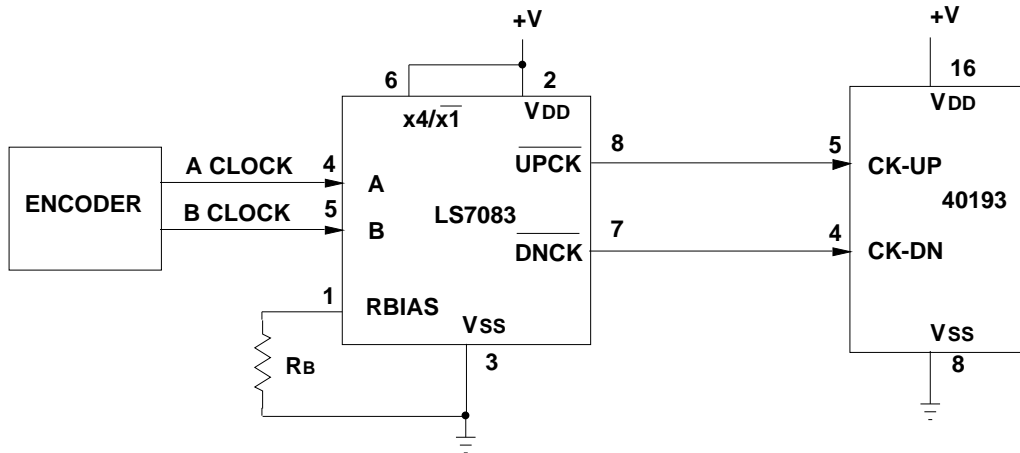

FIGURE 6A. TYPICAL APPLICATION FOR LS7083 IN x4 MODE

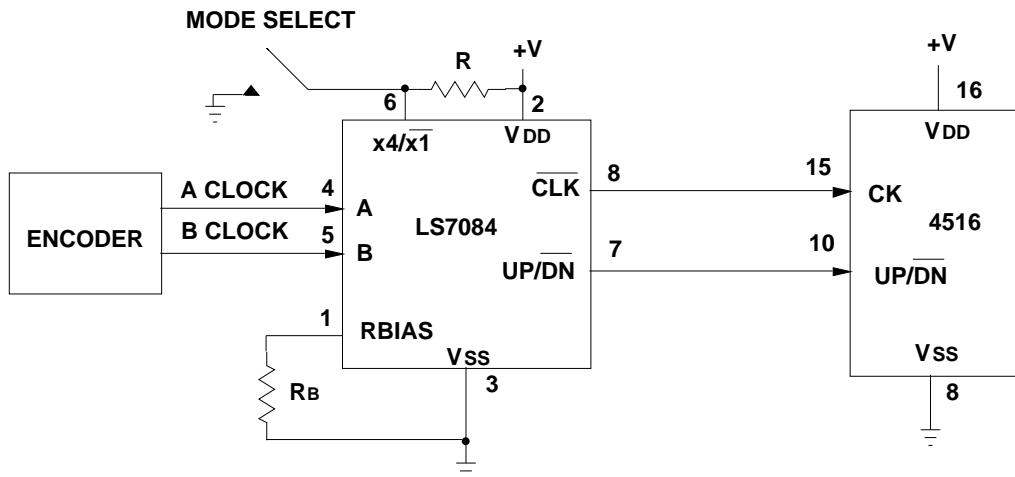

FIGURE 6B. TYPICAL APPLICATION FOR LS7084 WITH $x4/x1$ MODE SELECTION

Note: The $\overline{\text{CLK}}$ Output of LS7084 can be applied directly to the Clock Input of counters that advance on the positive edge of the Clock Input. If the Counter advances on the negative edge of the Clock Input, an inverter must be added between the $\overline{\text{CLK}}$ Output of LS7084 and the Clock Input of the Counter.