

DELAYED-OFF LIGHT SWITCH WITH PROGRAMMABLE ON-TIMER

November 2004

FEATURES:

- Phase-Lock Loop Synchronization allows use in Wall Switch Applications.
- Operation automatically sequences from Timed-On to Delayed-Off to Off.
- On-Timer programmable with external R-C.
- Transition from Timed-On to Delayed Off indicated by 31% drop in Delivered Power.
- Delayed-Off period denoted by Dim-to-Off operation. (See Note 1)
- Control input initiates Operating Sequence and can override Automatic Sequencing.
- 50/60Hz Line Frequency.
- +12V to +18V Operation ($V_{SS} - V_{DD}$).
- LS7338 (DIP); LS7338-S (SOIC) - See Figure 1

NOTE 1: Dim-to-Off time is Mask Programmable. The standard IC is fixed at 209 seconds for 60Hz. Dim-to-Off time can be programmed within a range of 6.5 to 836 seconds.

APPLICATIONS:

- WALL SWITCH for incandescent lighting in garage, corridor, staircase, child's bedroom, teenage study area.
- IN-LINE SWITCH for table lamps.

DESCRIPTION:

The LS7338 is a MOS integrated circuit designed to turn a triac On and Off in a Power Switch for Incandescent Lighting. Activation of \overline{SENSE} or SLAVE inputs turns the triac On and starts a timer. The triac remains On for the duration of the Timer which is controlled by an external R-C connected to the OSCILLATOR input. When Time-out occurs, the power delivered by the triac is stepped down by 31% and then slowly reduced to Off over a fixed period of time.

In a typical application (Figure 5), the output of the LS7338 drives the gate of a triac in series with the load.

There are three states through which the LS7338 can be stepped. The states and their corresponding operating mode, phase angles and delivered power levels are shown in Table 1.

TABLE 1

(See Figures 2 and 3)	STATE 0	STATE 1	STATE 2
OPERATING MODE	OFF	Timed-On	Delayed -Off
PHASE ANGLE, ϕ	No Output	159°	107° to 41°
% LOAD POWER (1)	0	99	68 to 7

(1) The percentage of full power delivered to a resistive load by the triac switch.

PIN ASSIGNMENT - TOP VIEW

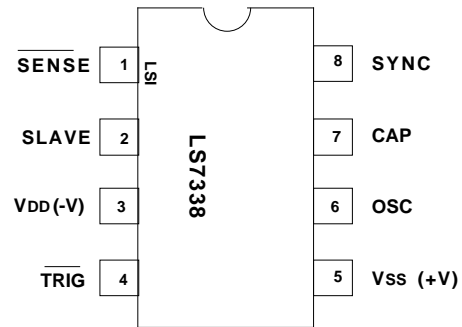

FIGURE 1

OPERATING DESCRIPTION:

Upon power up, internal power-on-reset starts the LS7338 in STATE 0. When the \overline{SENSE} input transitions to logic 0, or the SLAVE input transitions to logic 1, the IC steps to STATE 1. When implemented as shown in the application example (Figure 5), this is accomplished by touching the appropriate Sensor Plate. Subsequent similar transitions at \overline{SENSE} or SLAVE inputs cause the LS7338 to step through the sequence:

STATE 0 --> STATE 1 --> STATE 2 --> STATE 0, etc.

STATE 1 and STATE 2 are quasi-stable states. If left in STATE 1, after a time-out period determined by the frequency set at the OSC input (See I/O Description, Pin 6), the IC automatically steps to STATE 2. (If the OSC input is deactivated, STATE 1 becomes stable and its OPERATING MODE is denoted as On). When the IC steps from STATE 1 to STATE 2, the output phase angle ϕ changes from 159° to 107°. This corresponds to a delivered power reduction of 31%, which causes a reduction of lamp brightness. This brightness change provides the user with a positive indication that the transition from STATE 1 to STATE 2 has occurred. The Time-out period for STATE 2 is fixed at 209 seconds for 60Hz operation. (See Note 1.)

T_{D1} = STATE 1 Time-out period.
 T_{D2} = STATE 2 Time-out period.

During the STATE 2 Time-out, the \overline{TRIG} phase angle ϕ (See Figure 2) is ramped down from 107° to 41° in decrements of 1.4°. When ϕ reaches 41°, the IC automatically steps to STATE 0, shutting the \overline{TRIG} and lamp Off.

The slow Dim-to-Off in STATE 2 gives the user a continuing reminder that Delayed-Off is operating and provides the time and light with which to leave the area or to recycle the Light Switch. A new operating sequence from STATE 0 can be started only by transitions at the \overline{SENSE} and SLAVE inputs.

INPUT/OUTPUT DESCRIPTION:**SENSE** (Pin 1)

A logic 0 applied to this input for a minimum of three SYNC cycles, TS1 (50ms for 60Hz, 60ms for 50Hz), causes the circuit to step to the next state in the operating sequence.

SLAVE (Pin 2)

Same description as SENSE (Pin 1) except that logic 1 replaces logic 0. This input is designed to be used with Remote Extensions (See Figure 5 and Figure 6.)

VDD (Pin 3)

Supply voltage negative terminal.

TRIG (Pin 4)

TRIG is a negative-going pulse occurring once every half cycle of the SYNC input. Pulse width is 33 μ s. Table 1 in the General Description shows values of the TRIG phase angle for the different states. (See Figure 2 and Figure 3.)

Vss (Pin 5)

Supply voltage positive terminal.

OSC (Pin 6)

An R-C network connected to this input controls the frequency of oscillation which determines the Time-out, TD1, in State 1. TD1 is approximately 255RC. The Oscillator is active only in State 1. Chip to chip Oscillation Tolerance is $\pm 10\%$ for fixed value of RC. Tie Pin 6 to Vss if a Time-out is not desired. (See Figure 5.)

CAP (Pin 7)

The CAP input is for external component connection for the PLL filter capacitor. (See Figure 5.)

SYNC (Pin 8)

The AC Line Frequency (50/60Hz) is applied to this input. The Phase-Lock Loop synchronizes all internal timings to the AC signal at the SYNC input. (See Figure 5.)

ABSOLUTE MAXIMUM RATINGS:

PARAMETER	SYMBOL	VALUE	UNIT
DC supply voltage	VSS - VDD	+20	V
Any input voltage	VIN	VSS - 20 to VSS + 0.5	V
Operating temperature	TA	0 to +85	°C
Storage temperature	TSTG	-65 to +150	°C

DC ELECTRICAL CHARACTERISTICS:

(TA = 25°C, all voltages referenced to VDD)

PARAMETER	SYMBOL	MIN	TYP	MAX	UNIT	CONDITIONS
Supply Voltage	VSS	+12	-	+18	V	-
Supply Current	ISS	-	1.6	2.2	mA	VSS = +15V, Output off
Input Voltages						
SYNC Lo	VIRL	0	-	VSS - 9.5	V	-
SYNC Hi	VIRH	VSS - 5.5	-	VSS	V	-
<u>SENSE</u> Lo	VIOL	0	-	VSS - 8	V	-
<u>SENSE</u> Hi	VIOH	VSS - 2	-	VSS	V	-
SLAVE Lo	VIVL	0	-	VSS - 8	V	-
SLAVE Hi	VIVH	VSS - 2	-	VSS	V	-
Input Current						
SYNC, <u>SENSE</u> & SLAVE Hi	I _{IH}	-	-	110	uA	With Series 1.5M Resistor to 115VAC
SYNC, <u>SENSE</u> & SLAVE Lo	I _{IL}	-	-	100	nA	-
<u>TRIG</u> Hi Voltage	VOH	-	VSS	-	V	-
<u>TRIG</u> Lo Voltage	VOL	-	VSS - 8	-	V	VSS = +15V
<u>TRIG</u> Sink Current	I _{OS}	25	-	-	mA	VSS = +15V, VOL = VSS - 4V

TRANSIENT CHARACTERISTICS (See Fig. 2 and 3)

(All timings are based on Fs = 60Hz, unless otherwise specified.)

PARAMETER	SYMBOL	MIN	TYP	MAX	UNIT
SYNC Frequency	Fs	40	-	70	Hz
SENSE/SLAVE Sense Time	Ts1	50	-	Infinite	ms
<u>TRIG</u> Pulse Width	Tw	-	33	-	μ s
STATE 1 Time-out period	TD1	-	255RC	-	s
STATE 2 Time-out period	TD2	-	209	-	s

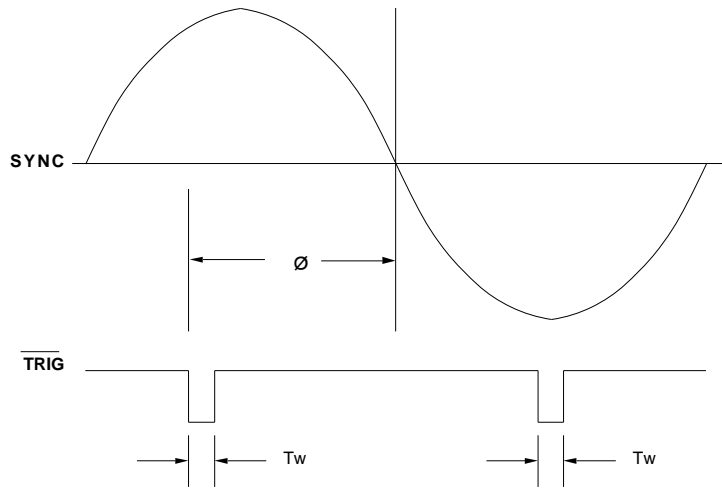

FIGURE 2. OUTPUT CONDUCTION ANGLE, \emptyset

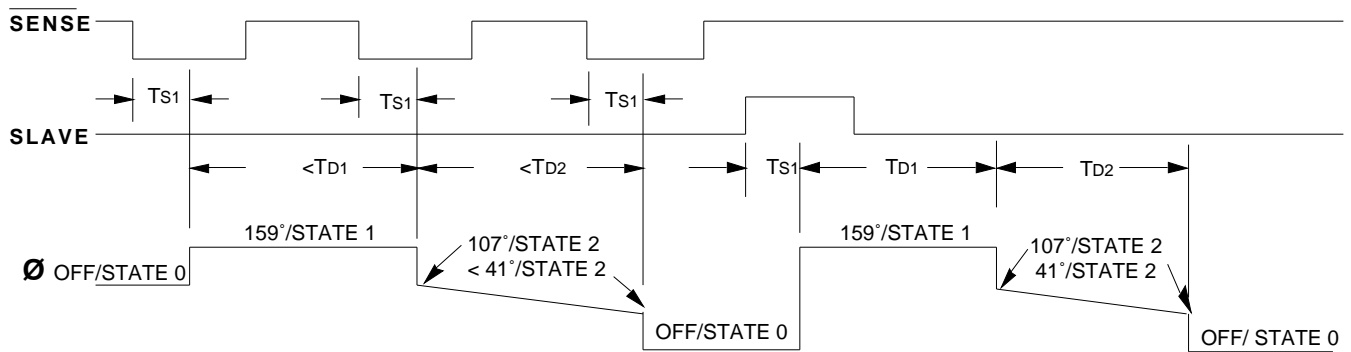

FIGURE 3. OUTPUT PHASE ANGLE \emptyset vs SENSE AND SLAVE

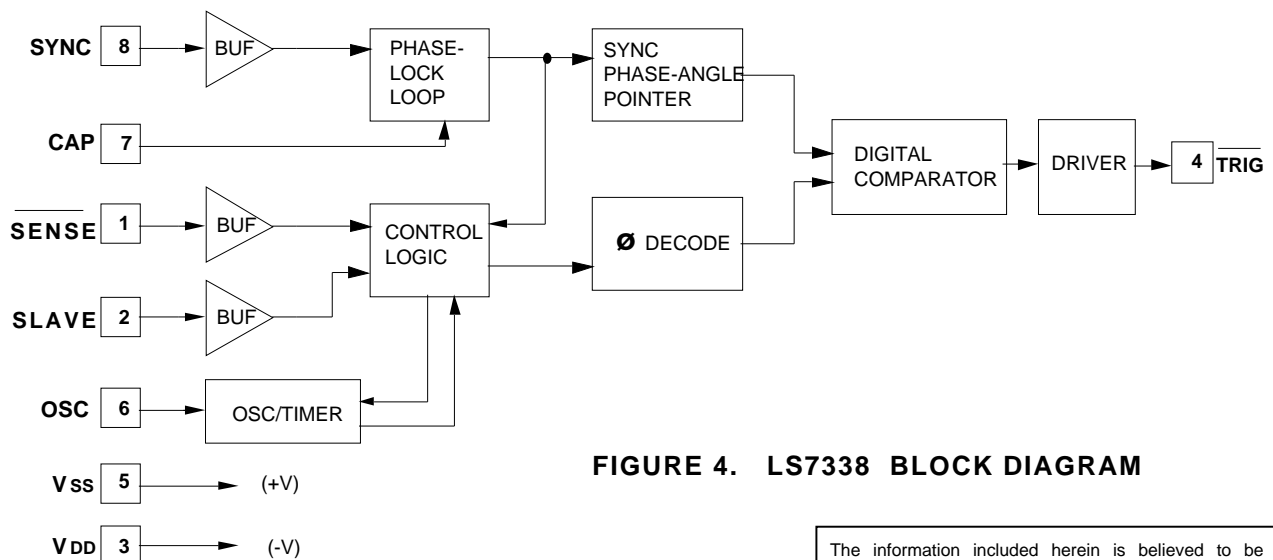
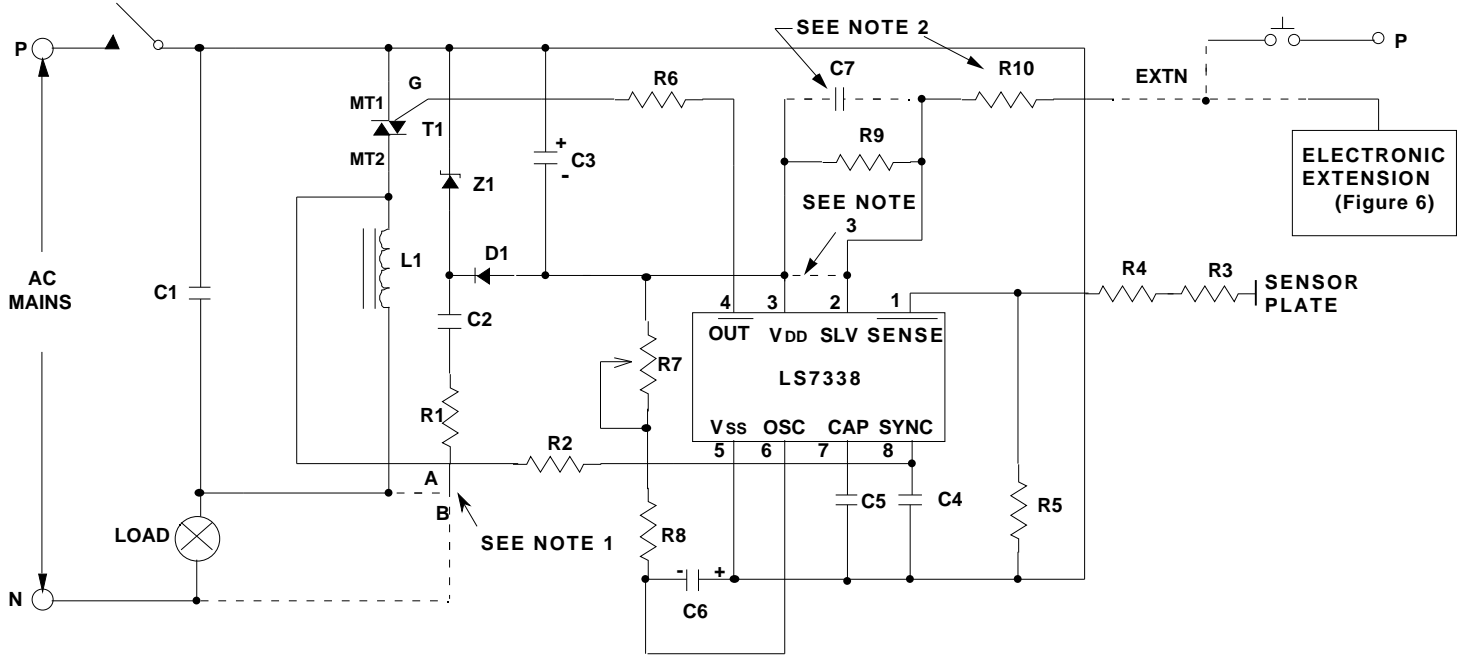

FIGURE 4. LS7338 BLOCK DIAGRAM

The information included herein is believed to be accurate and reliable. However, LSI Computer Systems, Inc. assumes no responsibilities for inaccuracies, nor for any infringements of patent rights of others which may result from its use.

FIGURE 5. A TYPICAL LIGHT SWITCH APPLICATION



NOTES:

1. Use Connection A when Neutral is not available. Use Connection B when Neutral is available.
2. C7 is used only with Electronic Extension. R10 is used only with Pushbutton Switch.
3. Connection between Pin 2 and Pin 3 is removed when SLAVE input is used.
4. See Table 2 for Component Functional Description

	115VAC	220VAC		115VAC	220VAC
(1) R1	270 , 1W	1k , 2W	(1) C2	0.33µF, 200V	0.22µF, 400V
(2) R1	82	82	(2) C2	0.22µF, 200V	0.1µF, 400V
R2	1.5M	1.5M	C3	47µF	47µF
R3	2.7M	4.7M	C4	470pF	470pF
R4	2.7M	4.7M	C5	0.047µF	0.047µF
(3) R5	1M to 5M	1M to 5M	C6	(5)	(5)
R6	100	100	C7	0.1µF, 200V	0.1µF, 400V
R7	(4)	(4)	Z1	15V, 1/2W	15V, 1/2W
R8	(4)	(4)	D1	1N4148	1N4148
R9	1.5M	1.5M	L1	100µH	200µH
R10	150k	150k	(6) T1	Q4008L4	Q5004L4
C1	0.15µF, 200V	0.15µF, 400V			

(1) Connection A (2) Connection B (3) Select for desired touch sensitivity (4) 100k (R7 + R8) 10M (5) (R7 + R8)C6 5ms (6) Typical

All Resistors 1/4W, all Capacitors 25V unless otherwise specified

**TABLE 2 .
FIGURE 5 COMPONENT FUNCTIONAL DESCRIPTION**

COMPONENTS	FUNCTIONAL DESCRIPTION
Z1, D1, R1, C2, C3	DC Power Supply.
R2, C4	Current limit and filter AC for SYNC input.
C1, L1	RFI filtering for AC Mains.
C5	PLL filter capacitor.
R3, R4, R5	Network sets the Touch Sensitivity for the SENSE input.
R6	Current limiting and isolation between I C output and Triac Gate.
R7, R8, C6	Oscillator R-C network. Potentiometer R6 required only if providing user adjustment of Time-out, TD1.
R9, C7	Filter for the Electronic Extension
R10	Current limiting resistor for the Pushbutton Switch Extension.

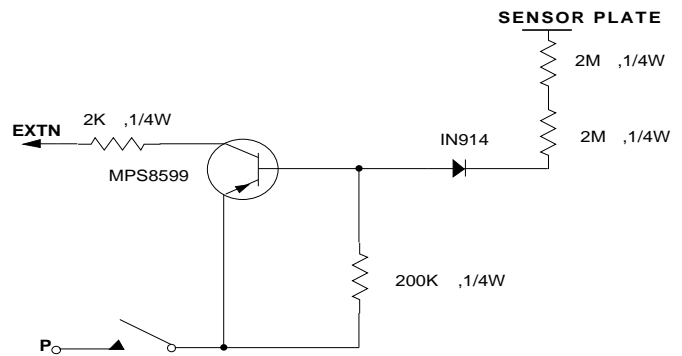

FIGURE 6. ELECTRONIC SWITCH EXTENSION

EXTENSIONS: (See Figure 5 and Figure 6)

All sequence functions can also be implemented by utilizing the SLAVE input. This can be done by either a pushbutton switch or the electronic switch in conjunction with a sensing plate as shown in Figure 6. When the plate is touched, a logic high level is generated at the EXTENSION terminal for both half cycles of the line frequency.