

BRUSHLESS DC MOTOR CONTROLLER

SEPTEMBER 2005

FEATURES

- Open loop motor control
 - Tachometer output for closed loop motor control
 - Error Amplifier and PWM Speed Comparator with full accessibility
 - High noise immunity Schmitt Triggers on Sensor inputs
 - 5.5V Reference Supply for external sensors
 - Cycle-by-cycle current sensing
 - Static, or current limited dynamic, motor braking
 - Output enable delay on speed direction reversal
 - Enable input with fault sensing capability
 - Fault Indicator output
 - 60°/300° or 120°/240° electrical sensor spacing selection
 - Selectable PWM of top and bottom drivers or bottom drivers only
 - CMOS compatible motor outputs with drive capability
 - Selectable top driver polarity
 - Low power dissipation
 - +10V to +18V Power Supply ($V_{DD} - V_{SS}$)
 - LS7560, LS7561 (DIP); LS7560-SD, LS7561-SD (Skinny DIP); LS7560-S, LS7561-S (SOIC); LS7560-TS, LS7561-TS (TSSOP)
- See Figure 1-

FIGURE 1. PIN CONNECTION DIAGRAM
TOP VIEW

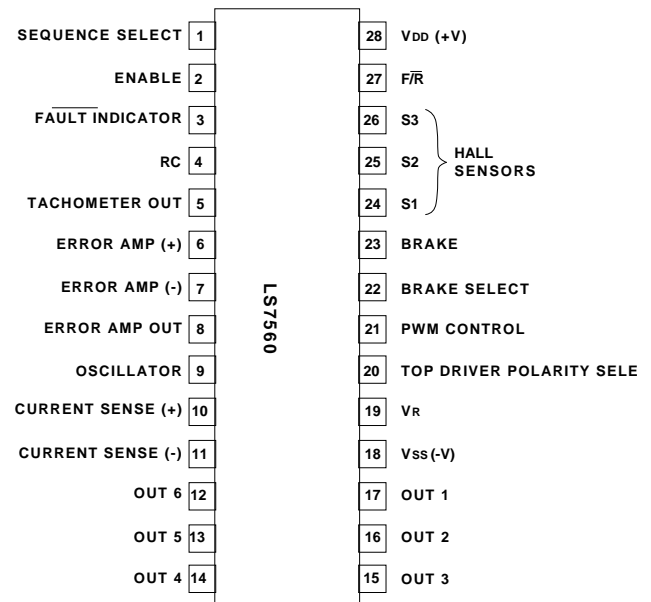

GENERAL DESCRIPTION

The LS7560/LS7561 are CMOS integrated circuits designed to control three or four phase brushless DC motors in a closed or open loop configuration. The IC consists of a decoder which provides proper commutation sequencing, a frequency-to-pulse width converter and error amplifier for closed loop motor speed control, a PWM comparator and sawtooth oscillator for external driver power control and a 5.5V reference generator for supplying power to motor sensors. Also included is Fault detection and indication, overcurrent sensing, dynamic motor braking, forward/reverse input, sensor spacing selections and an enable input control. The overcurrent sense condition will disable all output drivers when using the LS7560 and only the bottom drivers when using the LS7561.

The IC operates from 10V to 18V and provides CMOS compatible outputs for interfacing with external power devices. Operating below 10V will activate a Fault Indication Output and disable all Output Drivers.

INPUT/OUTPUT DESCRIPTION: (See Figure 2)

SEQUENCE SELECT Input (Pin 1)

A High on this input selects 60°/300° and a Low selects 120°/240° electrical sensor separation. Use of a 300° or 240° motor will cause opposite direction rotation as compared to a 60° or 120° motor.

F/R Input (Pin 27)

A High on this input selects Forward direction and a Low selects Reverse direction. The motor drive outputs are disabled for 2 clock cycles at the onset of a direction change.

S1, S2, S3 Inputs (Pins 24, 25, 26)

Hall Sensor inputs which are decoded to determine the Motor Commutation Sequence. An invalid input code disables all motor outputs. Inputs have Schmitt Trigger buffers for noise immunity.

BRAKE Input (Pin 23)

With the BRAKE SELECT input Low, a High on the BRAKE input forces the Top Drivers to an OFF condition and the Bottom Drivers to a PWM ON condition. If the Motor is under Closed Loop control, the Loop must be opened and the error amplifier output connected to the Error Amp (-) input. By controlling the voltage at the Error Amp (+) input, the PWM duty cycle is controlled during braking. This manner of braking prevents the Bottom Motor Drivers from drawing excessive current, a condition which can occur during normal braking (see Figure 8), when the Bottom Drivers are turned ON unconditionally. With the BRAKE SELECT input High, a High on the BRAKE input unconditionally causes the Top Drivers to turn OFF and the Bottom Drivers to turn ON. The BRAKE function has priority over all other functions.

BRAKE SELECT Input (Pin 22)

A Low on this input selects PWM control of braking and a High selects unconditional braking.

ENABLE Input (Pin 2)

When the ENABLE input is above $V_R/2$, all Output Drivers are enabled and when it is below $V_R/2.2$, all Output Drivers are disabled. This input has a nominal hysteresis of $0.05V_R$, where V_R is the internally generated Reference Voltage available on Pin 19. Because the ENABLE input is level sensitive, it can easily be used to control operation of the IC based on an Analog Fault Condition.

OSCILLATOR (Pin 9)

An external RC network is connected to this input to set the frequency of the Sawtooth Schmitt Trigger Oscillator. The Sawtooth is applied to the PWM Comparator along with the output of the Error Amplifier. The output of the PWM Comparator is a Pulse Width Modulated Signal which is used to vary the effective drive to the motor and, hence, the motor speed.

OVERCURRENT SENSE (Pins 10, 11)

The input to Pin 10 comes from the high side of a fractional ohm current sensing resistor. The voltage at this input is compared to an internal 100mV Reference. When the voltage exceeds the 100mV Reference, an Overcurrent Condition exists and the Output Drivers are switched OFF until the end of the sawtooth oscillator ramp-up. When the sawtooth switches low, the Overcurrent Condition is sampled, and if it no longer exists, the Output Drivers are switched ON again. Otherwise, the Output Drivers remain OFF until the end of the next sawtooth. The input to Pin 11 comes from the low side (Gnd) of the current sensing resistor and connects to the low side of the internal 100mV Reference.

PWM CONTROL Input (Pin 21)

A High on this input causes only the Bottom Drivers to be Pulse Width Modulated. A Low on this input causes both Top and Bottom Drivers to have PWM.

TACHOMETER Output (Pin 5)

The output of the Frequency To Pulse Width Converter is tied to this pin. The Converter uses the three SENSOR Inputs and external RC Network to generate a variable frequency output with a fixed positive pulse width.

RC Input (Pin 4)

The external RC network connected to this input programs the positive pulse width of the Frequency to Pulse Width Converter.

Vss (Pin 18)

Vss is Supply Voltage negative terminal.

ERROR AMPLIFIER Inputs (Pins 6, 7) **Output** (Pin 8)

For closed loop control, the TACHOMETER Output is applied through a resistor to the negative input of the Error Amplifier on Pin 7. A speed control potentiometer is connected to the positive input of the Error Amplifier on Pin 6. A parallel RC Network is connected between the Output of the Error Amplifier on Pin 8 and Pin 7. The Amplifier, configured this way, enables the variable pulse width to be converted to a DC voltage which is used to control the motor speed. The potentiometer is used to set the desired motor speed. For open loop control, configure the Error Amplifier as a voltage follower by connecting Pin 7 directly to Pin 8 and do not connect the TACHOMETER Output signal to the Error Amplifier.

TOP DRIVER POLARITY SELECT Input (Pin 20)

A High on this input selects a High Polarity for the Top Output Drivers Motor ON condition and a Low selects a Low Polarity.

OUTPUT DRIVERS (Pins 12, 13, 14, 15, 16, 17)

Each Driver Output provides a CMOS compatible signal for driving Buffers/Power Transistors. The Outputs are capable of sinking/sourcing 25mA with a 1.5V drop across the IC, at VDD = 12V.

FAULT INDICATOR Output (Pin 3)

Open drain output to provide sinking current for driving an external device, such as a LED through an emitter follower, to indicate a malfunction condition. The output occurs under any of the following conditions:

- 1) Overcurrent Sense condition
- 2) ENABLE Input below $V_R/2.2$
- 3) Invalid Sensor code
- 4) Chip power supply less than 9V
- 5) V_R Output less than 4.1V

Vr Output (Pin 19)

5.5V Reference Voltage Output that can supply 20mA of current at VDD = 12V for powering input Sensors.

VDD (Pin 28)

VDD is Supply Voltage positive terminal.

MAXIMUM RATINGS (Voltages referenced to Vss)

	SYMBOL	VALUE	UNIT
Power Supply Voltage	VDD	20	V
Voltage at any input	VIN	Vss - 0.5 to VR	V
Operating Temperature	TA	-25 to +85	°C
Storage Temperature	TSTG	-65 to +150	°C
Output Drive Sink/Source Current	Io	75	mA
VR Output Source Current	IR	30	mA

ELECTRICAL CHARACTERISTICS

VDD = 12V, RT = 47k , CT = 0.001µF, Rs = 10k , Cs = 0.01µF, RF = 47k (See Figure 3) TA = 25°C, unless otherwise specified

PARAMETER	SYMBOL	MIN	TYP	MAX	UNIT
Reference Voltage	VR	4.75	5.5	6.25	V
Line Regulation VDD = 10V to 18V, IREF = 1.0mA	VR	-	100	200	mV
Temperature Stability TA = 0°C to 70°C	VR	-	+/- 1.0	-	%
TA = 0°C to 85°C	VR	-	+/- 1.3	-	%
Error Amplifier:					
Input Offset Voltage	VIO	-	5	15	mV
Input Current	IIN	-	0	10	nA
Input Common Mode Voltage Range	VICR	(0 to VR)			V
Open Loop Voltage Gain (RL = 15k)	AVOL	70	80	-	dB
Common Mode Rejection Ratio	CMRR	60	-	-	dB
Power Supply Rejection Ratio	PSRR	60	-	-	dB

PARAMETER	SYMBOL	MIN	TYP	MAX	UNIT
Output High State (RL = 15k to Ground)	VOH	VR	-	-	V
Output Low State (RL = 15k to VR)	VOL	-	-	1.0	V
Output Source or Sink Current	Io	-	-	1.0	mA
Oscillator:					
Oscillator Frequency	Fosc	21	24	27	kHz
Percentage Frequency Change per Volt (VDD = 10V to 18V)	$\frac{F_{osc}}{F} / V$	-	0.4	1.0	%/V
Sawtooth High Voltage	VOSCP	-	3.8	4.5	V
Sawtooth Low Voltage	VOSCV	0.7	1.0	-	V
Capacitor Discharge Current	ID	0.6	1.0	2.5	mA
Logic Inputs:					
Input Threshold Voltage	VIH	3.0	2.3	-	V
(Pins 1, 20, 21, 22, 23, 24, 25, 26, 27)	VIL	-	1.8	1.4	V
Brake and Sensor (Pins 23, 24, 25, 26)					
High State Input Current (VIN = 4V)	IiH	-36	-27	-20	μA
Low State Input Current (VIL = 0V)	IiL	-50	-40	-30	μA
Sequence Select, Top Driver Polarity Select, PWM Control, Brake Select, and F/R Select (Pins 1, 20, 21, 22, 27)					
High State Input Current (VIN = 4V)	IiH	-16	-12	-8	μA
Low State Input Current (VIL = 0V)	IiL	-25	-17	-10	μA
ENABLE Input Threshold Voltage (Pin 2)					
Hysteresis	VH	0.2	0.3	0.4	V
ENABLE Input Current	IIN	-	-	10	nA
Overcurrent Sense Comparator:					
Input Threshold Voltage	VIH	80	100	120	mV
Input Current	IIN	-	-	10	nA
Outputs:					
Closed Loop Control Section:					
Tachometer Out					
Output High Voltage (Isource = 1.5mA)	VOH	VR - 0.8	VR - 0.5	VR - 0.3	V
Output Low Voltage (ISINK = 5mA)	VOL	0.18	0.27	0.40	V
Pulse Width	TW	95	105	115	μs
Capacitor Discharge Current (RC Terminal)	ID	1.8	3	7.5	mA
Output Drivers (Pins 12, 13, 14, 15, 16, 17)					
Sourcing 25mA	VOH	9.5	10.5	11	V
Sourcing 50mA	VOH	8	8.8	9.5	V
Sinking 25mA	VOL	1.0	1.30	2.0	V
Sinking 50mA	VOL	2.75	3.40	4.2	V
Switching Times	TR	30	45	60	ns
(CL = 250pF)	TF	35	50	65	ns
Switching Times	TR	100	150	200	ns
(CL = 1000pF)	TF	130	180	230	ns
FAULT Output Voltage (ISINK = 0.25mA)	VFO	-	-	0.3	V
FAULT Off-State Leakage	IF	-	10	-	nA
Under Voltage Lockout:					
For VDD					
Hysteresis	VH	0.45	0.65	0.85	V
For VR					
Hysteresis	VH	0.16	0.3	0.4	V
Power Supply Current					
VDD = 10V	IDD	-	2.0	2.5	mA
VDD = 12V	IDD	-	3.0	4.0	mA
VDD = 18V	IDD	-	7.0	11.0	mA

FIGURE 3. THREE PHASE CLOSED LOOP FULL WAVE MOTOR CONTROLLER

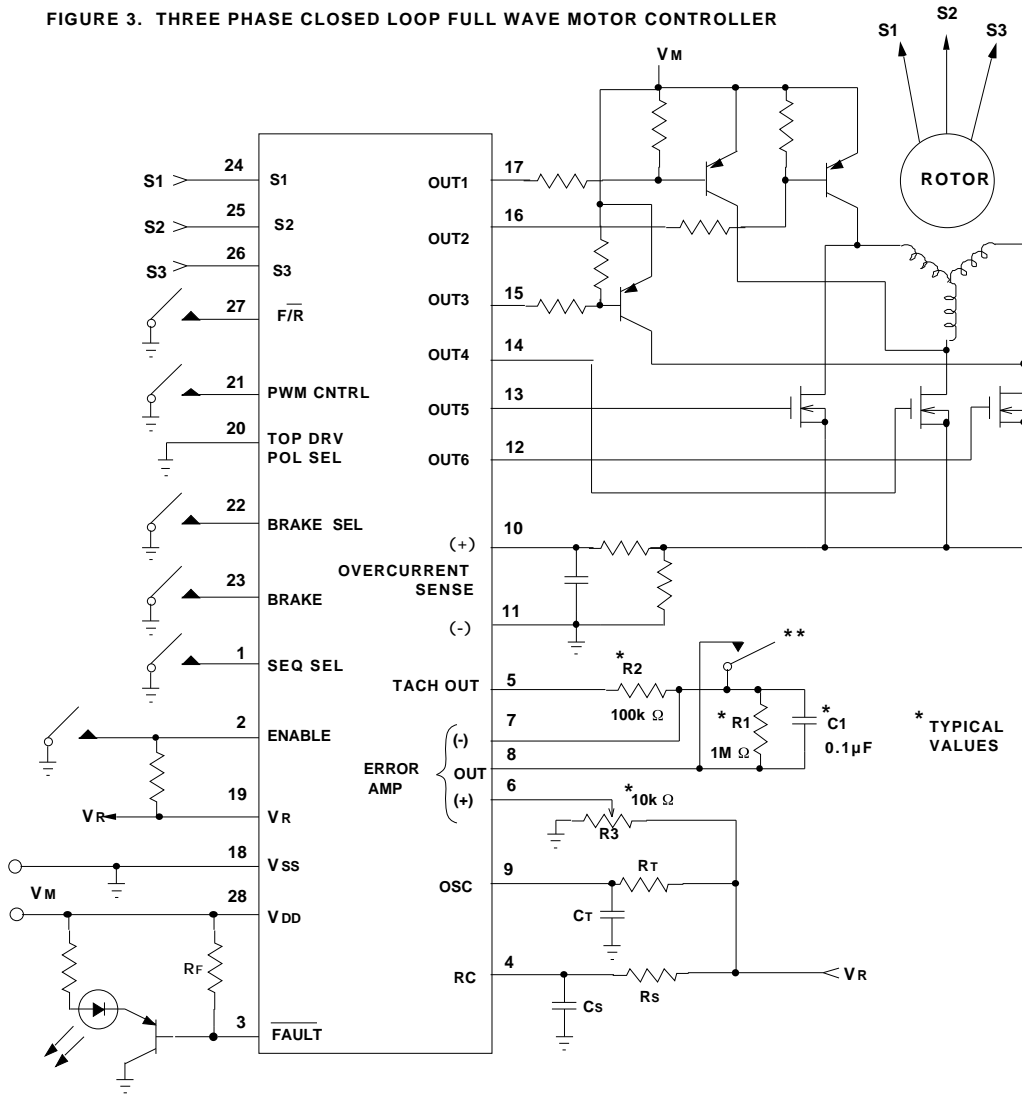

FIGURE 3. The closed loop motor control operation is achieved by applying the Tachometer Output at Pin 5 into the negative terminal of the Error Amplifier (Pin 7) through an R1-C1-R2 integrating network. The R1-C1 network is configured as a feedback circuit around the amplifier. Since the Tachometer Output has a fixed positive pulse width, the average value of the pulse train is directly proportional to the motor speed. The desired speed is selected by applying a voltage at the positive input (Pin 6) of the Error Amplifier. The resultant output voltage of the Error Amplifier is applied to an internal Comparator along with a ramp waveform generated by the RC Network at Pin 9. The PWM signal at the Comparator output is used to drive outputs 1 thru 6 and complete the closed loop. For this configuration, Pin 20, the Top Driver Polarity Select must be tied to Ground.

** Switch used to connect the error amplifier out and (-) input together when BRAKE SELECT input is low and BRAKE is applied. The speed setting selected by R3 also sets the PWM rate during braking.

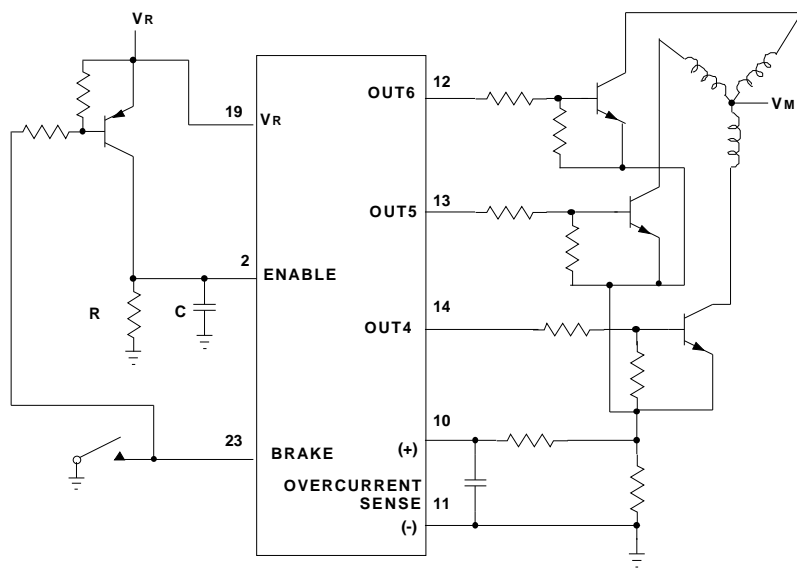

FIGURE 4. THREE PHASE HALF WAVE MOTOR CONTROLLER

FIGURE 4. This three phase half wave motor controller has no top power transistor to disconnect the windings from the power supply when the BRAKE is applied. Instead, a switching transistor is used which will permit braking for a time determined by the RC time constant. When the capacitor discharges past the ENABLE input switching point, the outputs will be turned off.

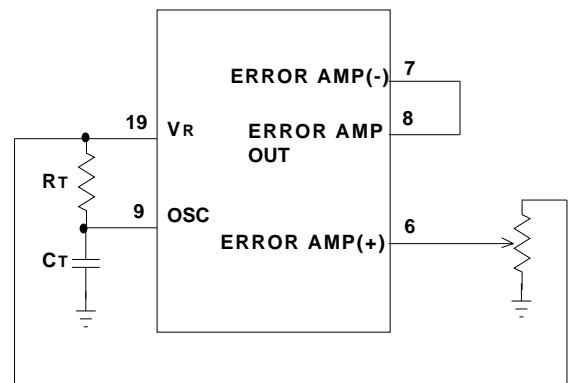

FIGURE 5. OPEN LOOP CONTROLLER

FIGURE 5. In this configuration, the PWM output duty cycle to the motor drivers is directly proportional to the DC voltage applied to Pin 6, since Pins 7 and 8 are tied together.

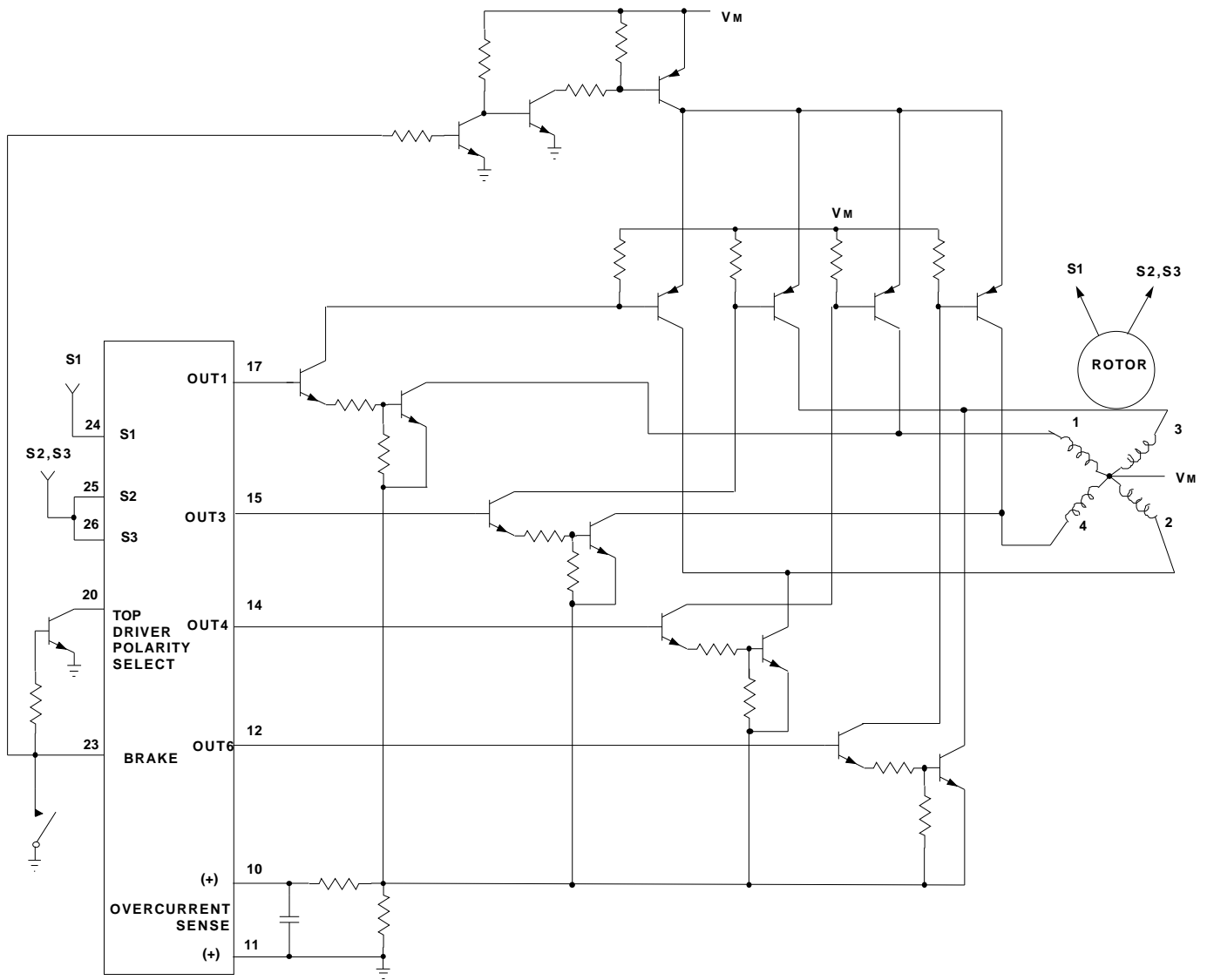

FIGURE 6. FOUR PHASE FULL WAVE MOTOR CONTROLLER

FIGURE 6. Four phase motor control requires only two Hall Sensor inputs spaced 90 electrical degrees apart. S1 is connected to one sensor and S2 and S3 are tied together and connected to the other sensor (Refer to Table 1). The BRAKE input (Pin 23) is used to control the Top Driver Select (Pin 20) and the Top Motor Drivers. When the BRAKE input is applied, the Top Motor drivers are turned off and the Top Driver Polarity Select is forced low turning on the Outputs 1 and 3. Since Outputs 4 and 6 are also turned on, the motor windings become shorted together.

The information included herein is believed to be accurate and reliable. However, LSI Computer Systems, Inc. assumes no responsibilities for inaccuracies, nor for any infringements of patent rights of others which may result from its use.

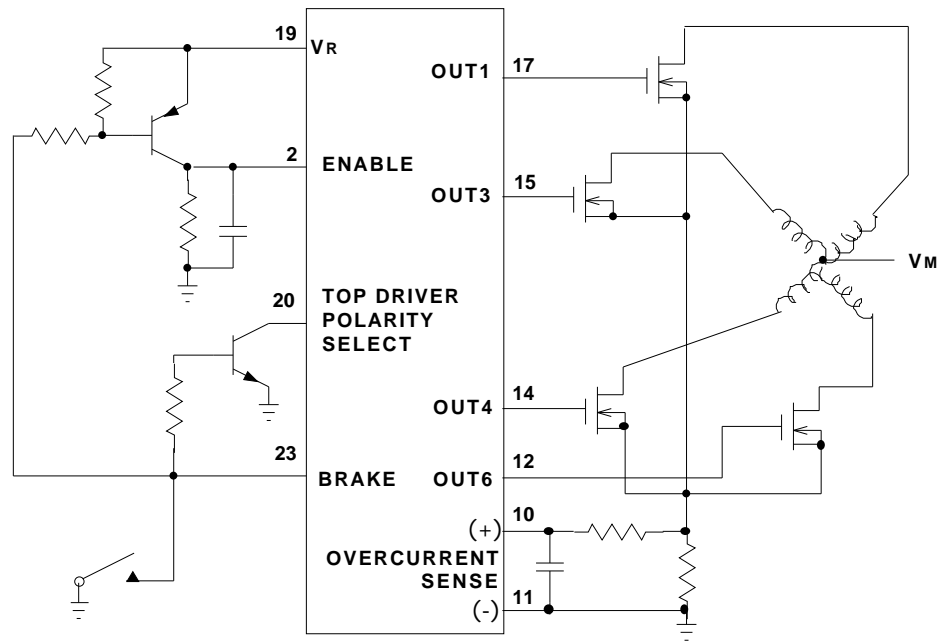

FIGURE 7. FOUR PHASE HALF WAVE MOTOR CONTROLLER

FIGURE 7. This four phase half wave motor controller uses the same BRAKE circuit as in Figure 4 and switches the Top Driver Select from a high to a low as in Figure 6.

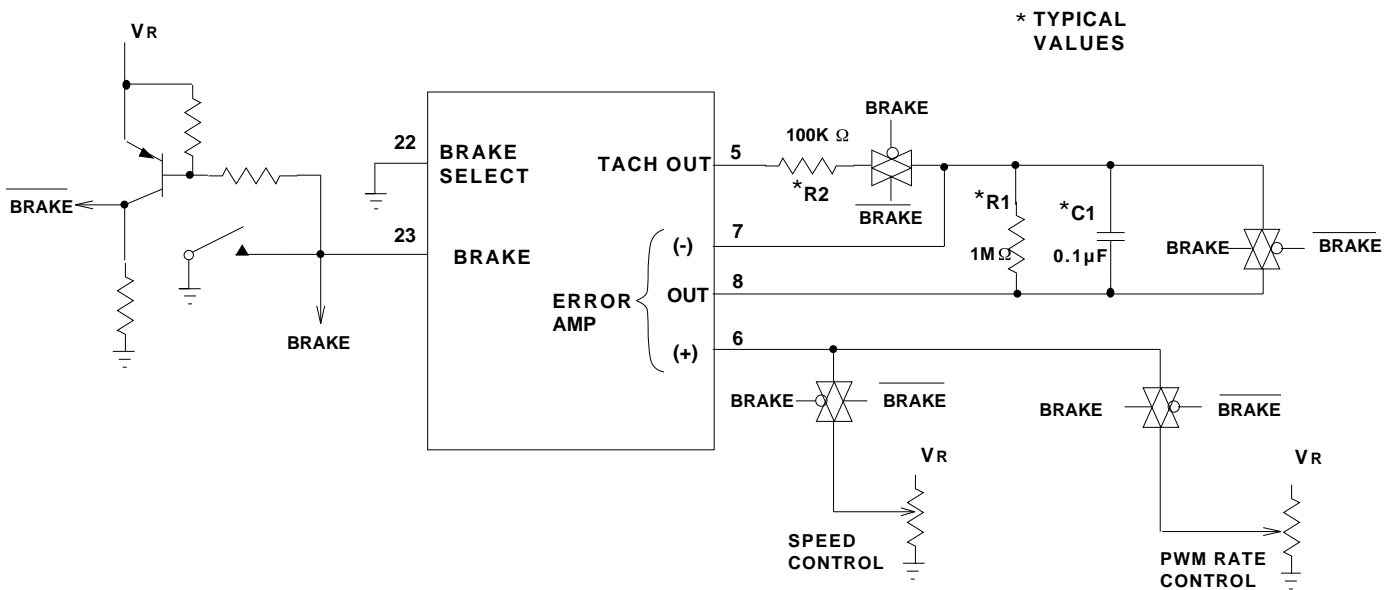

FIGURE 8. PWM BRAKING

FIGURE 8. Using an analog switch (such as the CD4066) PWM braking can be employed when the brake is applied. At that time, the error amplifier is configured as a voltage follower and its input is switched from the speed adjustment control to the PWM rate control. By adjusting the PWM rate control, the average motor current during braking can be controlled.

**TABLE 1. OUTPUT COMMUTATION SEQUENCE FOR THREE PHASE OPERATION
LS7560**

SENSOR ELECTRICAL SEPARATION			F/R	EN	BRK	OCS	TOP DRIVERS	BOTTOM DRIVERS	FAULT
60° S1, S2, S3	120° S1, S2, S3	O1, O2, O3					O4, O5, O6		
0 0 0	0 0 1	1	1	0	0	0 1 1	0 1 0	1	
1 0 0	1 0 1	1	1	0	0	1 1 0	0 1 0	1	
1 1 0	1 0 0	1	1	0	0	1 1 0	1 0 0	1	
1 1 1	1 1 0	1	1	0	0	1 0 1	1 0 0	1	
0 1 1	0 1 0	1	1	0	0	1 0 1	0 0 1	1	
0 0 1	0 1 1	1	1	0	0	0 1 1	0 0 1	1	
0 1 0	0 0 0	X	X	0	X	1 1 1	0 0 0	0	
1 0 1	1 1 1	X	X	0	X	1 1 1	0 0 0	0	
0 0 0	0 0 1	0	1	0	0	1 0 1	1 0 0	1	
1 0 0	1 0 1	0	1	0	0	1 0 1	0 0 1	1	
1 1 0	1 0 0	0	1	0	0	0 1 1	0 0 1	1	
1 1 1	1 1 0	0	1	0	0	0 1 1	0 1 0	1	
0 1 1	0 1 0	0	1	0	0	1 1 0	0 1 0	1	
0 0 1	0 1 1	0	1	0	0	1 1 0	1 0 0	1	
0 1 0	0 0 0	X	X	0	X	1 1 1	0 0 0	0	
1 0 1	1 1 1	X	X	0	X	1 1 1	0 0 0	0	
X X X	X X X	X	X	1	X	1 1 1	1 1 1	1	
X X X	X X X	X	X	0	1	1 1 1	0 0 0	0	
X X X	X X X	X	0	0	X	1 1 1	0 0 0	0	

EN = ENABLE
BRK = BRAKE
OCS = OVER CURRENT SENSE

NOTE 1: This Table assumes the TOP DRIVER POLARITY SELECT (Pin 20) = Logic 0.
For Pin 20 = Logic 1, invert the polarity of the top drivers.

NOTE 2: For the LS7561, the OVERCURRENT SENSE = Logic 1 only forces the bottom drivers to a Logic 0.
It has no effect on the top driver outputs which are determined by the other inputs as shown in the table.

**TABLE 2. OUTPUT COMMUTATION SEQUENCE FOR FOUR PHASE OPERATION
LS7560**

SENSOR ELECTRICAL SEPARATION = 90°			F/R	EN	BRK	OCS	TOP DRIVERS	BOTTOM DRIVERS	FAULT
S1	S2, S3	O1, O3					O4, O6		
0	0	1	1	0	0	1 0	0 0	1	
1	0	1	1	0	0	0 1	0 0	1	
1	1	1	1	0	0	0 0	1 0	1	
0	1	1	1	0	0	0 0	0 1	1	
0	0	0	1	0	0	0 0	1 0	1	
1	0	0	1	0	0	0 0	0 1	1	
1	1	0	1	0	0	1 0	0 0	1	
0	1	0	1	0	0	0 1	0 0	1	
X	X	X	X	1	X	0 0	1 1	1	
X	X	X	X	0	1	0 0	0 0	0	
X	X	X	0	0	X	0 0	0 0	0	

EN = ENABLE
BRK = BRAKE
OCS = OVER CURRENT SENSE

NOTE 1: SEQUENCE Input (Pin 1) set at a Logic 1.

NOTE 2: This Table assumes the TOP DRIVER POLARITY SELECT (Pin 20) = Logic 1. For Pin 20 = Logic 0, invert the polarity of the top drivers.

NOTE 3: For the LS7561, the OVERCURRENT SENSE = Logic 1 only forces the bottom drivers to a Logic 0. It has no effect on the Top Driver Outputs which are determined by the other inputs as shown on the table.