

REVERSE PHASE (TRAILING-EDGE) HALOGEN LAMP DIMMER

June 2009

FEATURES:

- Pushbutton or touch control of high-voltage lamps and **all electronic transformer-coupled** low-voltage halogen lamps.
- Controls **Fluorescents** and **CFLs** via dimming ballasts.
- Reverse-phase technology **eliminates RFI** generation.
- "FO" versions power up **Full On** after application of AC.
- Soft turn-on and soft turn-off
- Three operating modes.
- Inputs for direct or remote activation.
- 50Hz/60Hz AC line frequency.
- +12V Power Supply (VDD - VSS).
- **LS7636, LS7637** (DIP); **LS7636-S, LS7637-S** (SOIC);
LS7636FO, LS7637FO (DIP);
LS7636FO-S, LS7637FO-S (SOIC) - See Figure 1 -

APPLICATIONS:

Electronic dimmers for wall-switch control of ceiling mounted lighting, foot-switch control of large floor lamps and hand-switch control of table lamps.

BACKGROUND AND GENERAL DESCRIPTION:

Since the operating currents of some electronic transformers are below the holding current of most triacs, a typical triac-based (leading-edge) dimmer may not operate properly when driving an electronic transformer-coupled low-voltage halogen lamp. The filtering components in the electronic transformer which prevent its operating frequency from generating line interference can also inhibit triac triggering. The **LS7636 LS7637** family of reverse-phase dimmer ICs drive FETs or IGBTs (see Figure 3 and Figure 4) and 'slowly' turns on current beginning at the AC input zero-crossing. This 'slow' current turn on is ideal for interfacing with the primary of **any** electronic transformer and also eliminates the RFI generation caused by the sudden turn on of current when using a triac-based dimmer.

INPUT/OUTPUT DESCRIPTION:

VDD (Pin 1) Supply voltage positive terminal.

Vss (Pin 7) Supply voltage negative terminal.

MODE (Pin 2) - See Table 1

All variations of **LS7636** and **LS7637** can operate in 3 different modes. The 3-state MODE input selects the operating modes:

Vss = Mode 0; Float = Mode 1; VDD = Mode 2

SYNC (Pin 4) - See Figure 2

The AC line frequency is applied to this input.
All internal timings are synchronized to the AC.

PIN ASSIGNMENT - TOP VIEW

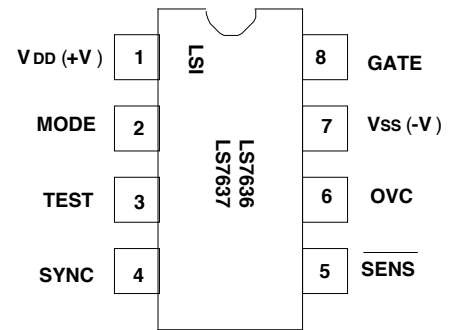

SENS (Pin 5) - See Table 1

A Logic 0 applied to this input alters the Gate Drive output either by turning it on, turning it off or by changing its conduction angle. Specifically which action takes place is dependent on the type of activation of the SENS input, namely SHORT or LONG duration and the prior state of the Gate Drive output.

OVC - Overcurrent Sense Input (Pin 6)

The voltage at this input is sampled every half-cycle in a four-cycle period. If the voltage reaches the OVC threshold four times, then the Gate Output is turned Off shutting down the current through the load. Six cycles after shutdown occurs, the output is turned On to the previous conduction angle, the OVC counter is reset and a new four-cycle period begins. The OVC voltage may be generated with a fractional-Ohm resistor as shown in Figure 4 and Figure 5. When OVC is not being used, Pin 6 must be tied to Pin 7.

Gate (Pin 8)

The Gate Drive output is a positive-going pulse that initiates at every zero-crossing of the AC input. The width of the Gate Drive signal determines the conduction angle as shown in Figure 2.

Test (Pin 3)

For factory use only.

The information included herein is believed to be accurate and reliable. However, LSI Computer Systems, Inc. assumes no responsibilities for inaccuracies, nor for any infringements of patent rights of others which may result from its use.

TIMING CHARACTERISTICS (See Figures 2, 3 and 4):

PARAMETER	SYMBOL	MIN	TYP	MAX	UNIT	CONDITION
SYNC Frequency	fs	40	-	70	Hz	-
SHORT Activation	TS1	50	-	417	ms	60Hz
	TS1	60	-	500	ms	50Hz
LONG Activation	TS2	433	-	Infinite	ms	60Hz
	TS2	520	-	Infinite	ms	50Hz
GATE DRIVE pulse width (see Note 5)	GDW	2.31	-	7.13	ms	60Hz
	GDW	2.78	-	8.56	ms	50Hz
Conduction Angle	\emptyset	50	-	154	deg	-
\emptyset incremental steps (Note 1)	\emptyset	-	1.4	-	deg	-
Soft-on slew rate	SS	-	1.4	-	deg / 33.3ms	60Hz
	SS	-	1.4	-	deg / 40ms	50Hz
A0 to A1/A2 to A0 slew rate (Note 2)	SAA	-	1.4	-	deg / 33.3ms	60Hz
	SBA	-	1.4	-	deg / 40ms	50Hz
A1 to B1/B2 to A2 slew rate (Note 3)	SBA	-	1.4	-	deg / 66.7ms	60Hz
	SBA	-	1.4	-	deg / 80ms	50Hz
B1 to B2 delay (Note 4)	TBD	-	500	-	ms	60Hz
	TBD	-	600	-	ms	50Hz

Note 1: Total number of steps = 77.

Note 2: Number of steps from A0 to A1, or A2 to A0 = 55.

Note 3: Number of steps from A1 to B1 or B2 to A2 = 21.

Note 4: \emptyset is at minimum between B1 and B2. TBD is applicable for **LS7636** only.

Note 5: For **LS7637** when minimum \emptyset is reached, dimming direction reverses only if the LONG Activation is terminated and reapplied.

The difference among all versions of **LS7636** and **LS7637** are:

LS7636 (LS7636FO)

Upon power-up, the Gate Drive output is Off.
(Upon power-up, the Gate Drive output is On at maximum conduction angle.) When a LONG Activation is applied, the dimming direction automatically reverses whenever maximum or minimum conduction angles are reached.

LS7637 (LS7637FO)

Upon power-up, the Gate Drive is Off.
(Upon power-up, the Gate Drive is On at maximum conduction angle.) When a LONG Activation is applied, the dimming stops whenever maximum or minimum conduction angles are reached. In order to change dimming levels from maximum or minimum, LONG Activation must be removed and reapplied. The purpose of this feature is to allow the user to positively locate maximum and minimum conduction angles.

LS7637 NOTE:

If the User applies a LONG Activation when the Gate Drive Conduction Angle is within a "few" degrees of Maximum or Minimum, the Gate Drive Conduction Angle can move to Maximum or Minimum and stop without the User being able to observe a change in brightness. Therefore, the User should be instructed that if no change in brightness is observed in response to a LONG Activation, the LONG Activation should be removed and reapplied in order to produce a change in brightness.

TABLE 1

MODE	SHORT-ACTIVATION		LONG-ACTIVATION		DIMMING REVERSAL (Note 5)
	PRE-ACTIVATION \emptyset	POST-ACTIVATION \emptyset	PRE-ACTIVATION \emptyset	POST-ACTIVATION \emptyset	
0	OFF ON	MAX (Note 1) OFF (Note 4)	OFF/MIN MAX INTERMEDIATE	Varies up from MIN Varies down from MAX Varies from INTERMEDIATE	N/A N/A NO
1	OFF ON	MEMORY (Notes 2, 3) OFF (Note 4)	OFF/MIN MAX INTERMEDIATE	Varies up from MIN Varies down from MAX Varies from INTERMEDIATE	N/A N/A YES
2	OFF ON	MAX (Note 1) OFF (Note 4)	OFF/MIN MAX INTERMEDIATE	Varies up from MIN Varies down from MAX Varies from INTERMEDIATE	N/A N/A YES

Note 1: A soft turn-on is produced by slewing up the conduction angle, \emptyset , from minimum at the rate of 1.4° / 33.3ms (60Hz).

Note 2: A soft turn-on is produced by slewing up \emptyset , from minimum to memory.
Upon power-up the memory value is defaulted to maximum conduction angle.

Note 3: "Memory" refers to the conduction angle, \emptyset , which existed prior to the current off-state.

Note 4: A soft turn-off is produced by slewing down \emptyset from the existing conduction angle to off at the rate of 1.4° / 33.3ms (60Hz).

Note 5: **NO** = Dimming direction does not reverse from prior dimming direction.
YES = Dimming direction does reverse from prior dimming direction. **N/A** = Does not apply.

ABSOLUTE MAXIMUM RATINGS:

PARAMETER	SYMBOL	VALUE	UNIT
DC supply voltage	V _{DD} - V _{SS}	+16	V
Any input voltage	V _{IN}	V _{SS} - 0.3 to V _{DD} + 0.3	V
Operating temperature	T _A	0 to +90	°C
Storage temperature	T _{STG}	-65 to +150	°C

DC ELECTRICAL CHARACTERISTICS:

(T_A = +25°C, all voltages referenced to V_{SS}. V_{DD} = +12V unless otherwise noted.)

PARAMETER	SYMBOL	MIN	TYP	MAX	UNIT	CONDITION
Supply voltage	V _{DD}	10	12	15	V	-
Supply current	I _{DD}	-	0.8	1	mA	Output unloaded V _{DD} = +12V
SYNC Lo	V _{ISL}	-	-	5.7	V	-
SYNC Hi	V _{ISH}	6.4	-	-	V	-
SENS Lo	V _{IEL}	-	-	4.5	V	-
SENS Hi	V _{IEH}	7.7	-	-	V	-
GATE DRIVE						
Source Current	I _{GSR}	4	-	-	mA	V _{OH} = 11.5V
Sink Current	I _{GSN}	4	-	-	mA	V _{OL} = 0.5V
OVC		--	0.35	-	V	-

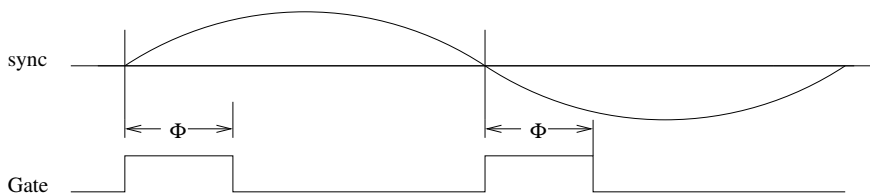

FIGURE 2. Gate Conduction Angle, Φ

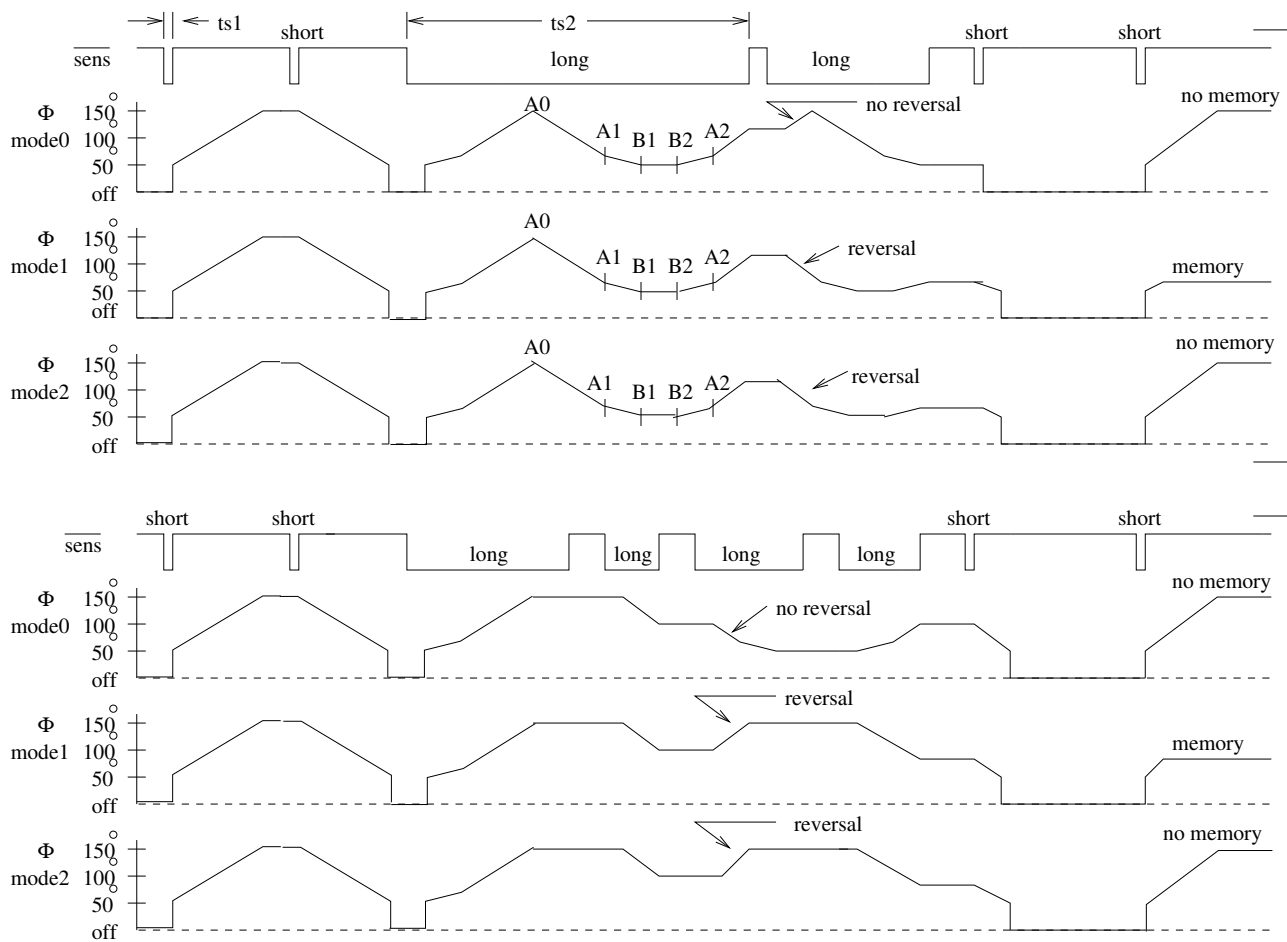

FIGURE 3. Gate Conduction Angle, Φ vs Sens

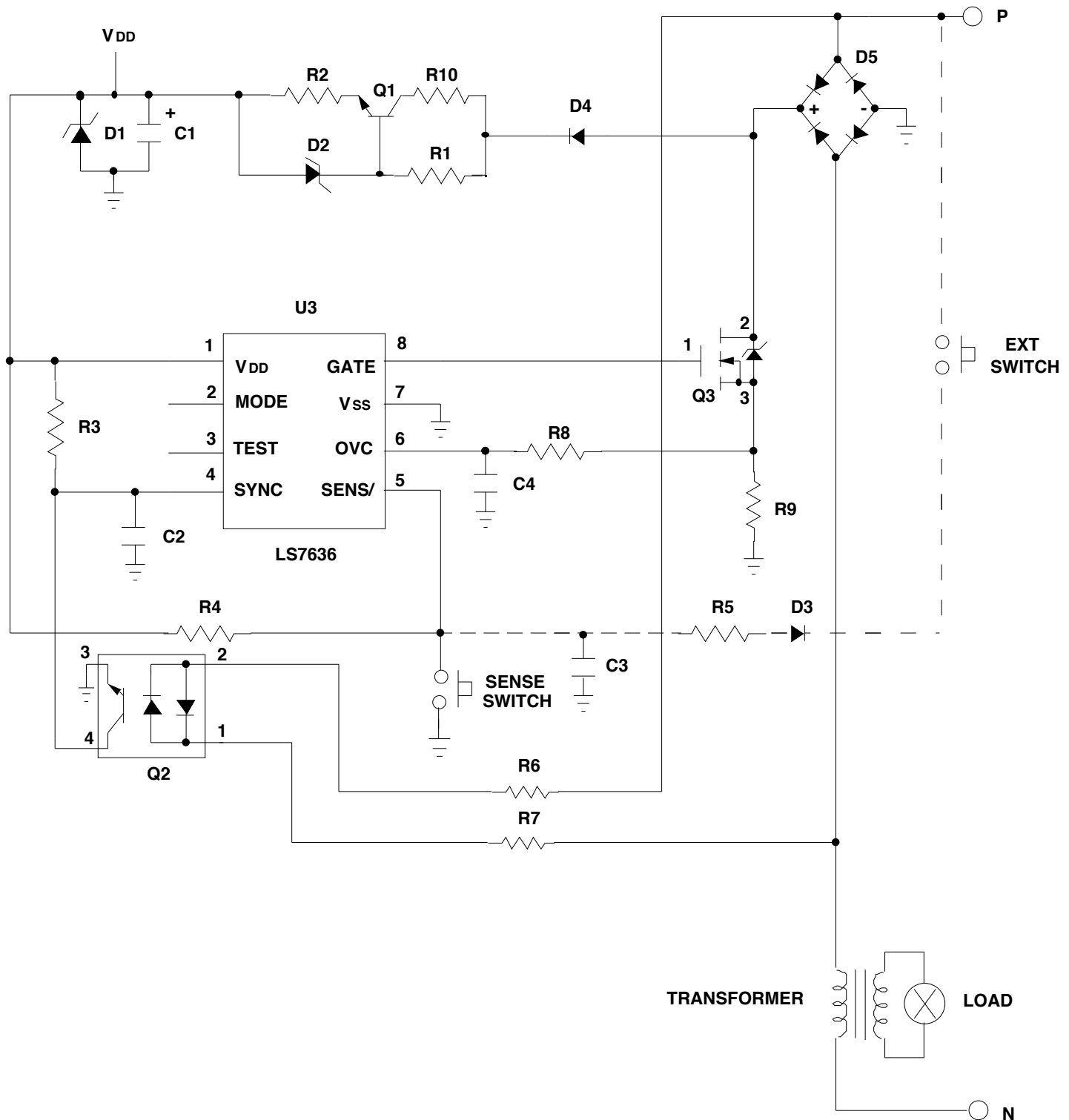

FIGURE 5. Reverse Phase Dimmer (Option 2)

- | | | |
|--------------------|------------------------------------|-------------------------------------|
| C1 = 100uF | R6 = 47k | D3 = 1N4004 |
| C2 = 0.0047uF | *R6 = 91k | D4 = 1N4004 |
| C3 = 0.047uF | R7 = 47k | D5 = DF02 |
| C4 = 0.1uF | *R7 = 91k | *D5 = DF04 |
| R1 = 150k | R8 = 10k | Q1 = MJE340 (or equivalent) |
| * R1 = 270k , 1/2W | R9 = 0.25 , 1W (For 1 Amp RMS Max) | Q2 = Liteon LTV354T (or equivalent) |
| R2 = 390 | R10 = 4.3k , 1/2W | Q3 = IRF630 (Typical) |
| R3 = 39k | D1 = 12V, 1/2W, 5% | *Q3 = IRF730 (Typical) |
| R4 = 1.5M | D2 = 5.6V, 1/4W, 10% | |
| R5 = 150k | | |

**All Resistors 1/4W, All Capacitors 25V unless otherwise specified
 * = Component change for 220VAC**

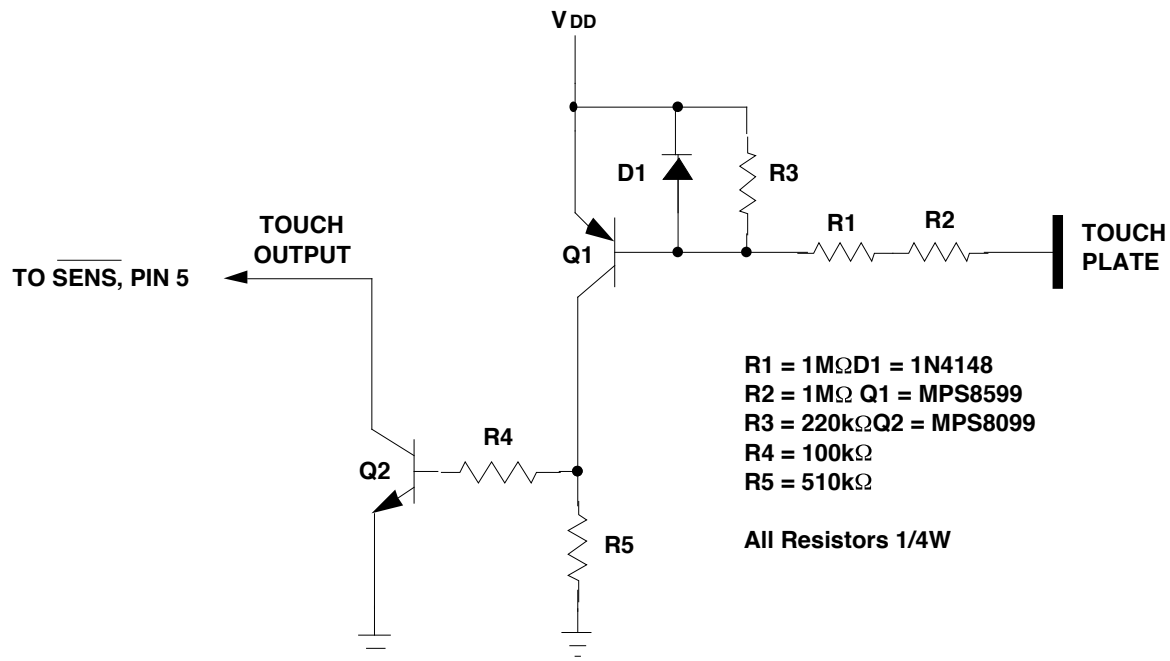

FIGURE 6. Application Circuit For Touch Control Operation

The Application Circuit shown in Figure 6 can be applied to the Reverse Dimmer circuits shown in Figure 4 (Option 1) and Figure 5 (Option 2). The Touch Output is connected to the SENSE input (Pin 5) of LS7636. When using the circuit shown in Figure 6, the following components must be removed in Figure 4 and Figure 5:

Figure 4 - Remove R6, D5, EXT SWITCH and SENSE SWITCH. C3 remains.

Figure 5 - Remove R5, D3, EXT SWITCH and SENSE SWITCH. C3 remains.